



Ye Olde
Tri GOVNSMAN Valley
 "The Best Journal Published by a Dam Site!"

VOL. 20 NO. 35 GRAHAMSVILLE, NY 12740 AUGUST 29, 2024

Mysterious Book Report John D. McKenna Pg 6 • *The Olive Jar* Carol La Monda Pg 7 • *The Scene Too* Jane Harrison Pg 11
Knarf's Classic Movie & Trivia Pg 78

Dwight Coombe –Citizen of the Year

Dwight Coombe, president of Sprague & Killeen, Inc in Ellenville, NY is being honored by the Noonday Club as the Ellenville 2024 Citizen of the Year. Dwight has been a large supporter of numerous ventures and activities in the Ellenville-Wawarsing area throughout his career. He cares deeply about people and the communities in which he lives and works.

The son of Phil Jr and Carolyn Coombe, Dwight is a lifelong resident of Grahamsville, NY. He grew up on the family farm where equipment repairs, maintenance, welding and the like were his strengths. Dwight still helps on the family farm as time allows. He is the father of two sons, Myles and Dustin, who also live in Grahamsville.

A graduate of Cornell University, Dwight studied business and received his degree in engineering. Out of college, he worked with his brother, Phil Coombe III, and obtained his life and health insurance license.

Dwight met Jack Killeen and the team at Sprague & Killeen, Inc and quickly decided he would like property and casualty insurance better - working with businesses, contractors, manufacturers, etc. as his engineering background fit in well for this field. In 1994, Dwight entered a contract with Jack to purchase Sprague & Killeen. As the current sole owner, Dwight continues to grow the business, licensed to operate in eight states, and proudly reinvests in maintaining the 1863 bank building that houses insurance firm. (Contd. Pg. 5)

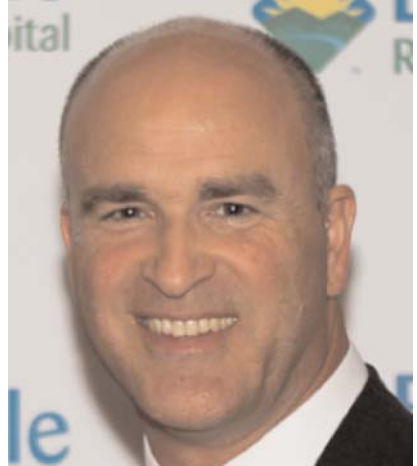

Vintage 19th Century Base Ball Games at the Grahamsville Fairgrounds

Sunday, September 8th, Noon • Sponsored by the Time and the Valleys Museum



Mountain Athletic Club playing at the Grahamsville Fairgrounds, 2019

[Grahamsville, N.Y.] - Two Vintage 19th Century Base Ball Games will be held at the Grahamsville Fairgrounds on St. Rt. 55 in Grahamsville on Sunday, September 8th at noon, sponsored by the Time and the Valleys Museum in Grahamsville. The Mountain Athletic Club of Fleischmanns faces off with the Connecticut Base Ball Club of Hartford for a double-header of 1864 and 1895 rules base ball.



Mountain Athletic Club team, 2024

Before each game, a brief talk will be given describing the differences between the rules in 1864 or 1895 and the rules today. "These are no ordinary ball games," states Collin Miller, captain of the Mountain Athletic Club. (Contd. Pg. 4)

YE OLDE TRI-VALLEY TOWNSMAN

OFFICIAL NEWSPAPER FOR
THE TOWN OF DENNING AND
THE TOWN OF NEVERSINK

Ye Olde Tri-Valley Townsman (ISSN 1558-9013) will be published weekly for \$40.00 per year by
Gnome Home Inc.

EDITOR: Linda Comando - 845-985-0501 or 845-985-3215
THE SCENE TOO - Jane Harrison

OLIVE JAR - Carol La Monda

MYSTERIOUS BOOK REPORT - John McKenna

MOVIE TRIVIA - Frank Comando a/k/a Knarf

COMMUNITY NEWS - Sheila Lashinsky

Email: tvtownsman@yahoo.com

Website: thetownsman.com

Subscription for *The Townsman* will be available in pdf format and will be delivered to you each week in your email that will be provided by you. *The Townsman* can easily be read on a computer, tablet or cell phone. The pages have been formatted so they can be printed out as a whole paper or a single page. We continue to encourage those who have home printers, to print out a hard copy and perhaps pass it on to a family member or friend who does not have a computer.

**POLICY ON SUBMISSIONS AND
LETTERS TO THE EDITORS:**

1. **ALL submissions** should be typewritten or in Microsoft Word.
2. Letters should contain no more than 300 words and must be typewritten. They may be emailed as Microsoft Word documents.
3. Letters should offer worthwhile comments and avoid libel or bad taste.
4. Letters must be signed with the writer's own name. No letter will be published without a signature.
5. The writer must provide his/her full name, address and telephone number (for verification). This information will be kept on file in the Gnome Home Inc. office. Telephone numbers will not be published.
6. Copies of letters or third-party letters will not be accepted.

Opinions expressed in *Ye Olde Tri-Valley Townsman* belong to the writers and are not necessarily the viewpoint of *Ye Olde Tri-Valley Townsman* or its staff.

To renew or receive a new subscription

to the *Virtual TOWNSMAN*, sent to your email every week, print this form then fill out it out and mail it to: Townsman, P.O. Box 232, Grahamsville, NY. Make checks payable to: *Ye Olde Tri-Valley Townsman*. You may also sign up on line with **Paypal** Go to our website: <http://thetownsman.com>

NAME _____

EMAIL _____

PHONE _____

SUBSCRIPTIONS: **\$40.00 PER YEAR**

NEW RENEWAL/DATE EXP. _____

Check # _____

Subscription/renewals must be received by the last Saturday of the month preceding your renewal date to avoid interruption of your subscription.

A change of an email address must be received a month prior to change in order to make the necessary changes in our computer system. All changes are the responsibility of the subscriber.

ADVERTISING DEADLINE:

3:00 P.M. MONDAYS – FIRM

Rates are based on **Camera-ready copy**. **All advertising must be pre-paid** unless other arrangements have been made.

Please send your ad copy to: tvtownsman@yahoo.com or by regular mail to: **The Townsman**, PO Box 232, Grahamsville, NY 12740

Deadline for all submissions is 3:00 p.m. Monday for the current week's issue

NO EXCEPTIONS. All press releases/articles sent by email should be sent as **Microsoft Word Documents**. Photos or graphics must be in jpg or pdf format

More than ever, thank you for your continued support.

ON THE FRONT BURNER: Thus saith the Lord of hosts, behold, evil shall go forth from nation to nation, and a great whirlwind shall be raised up from the coasts of the earth.
Jeremiah 26:32

Lighting of the Fire Towers 2024

The 11th annual "Lighting of the Fire Towers" will take place on the night of Saturday, August 31, 2024. The Red Hill Fire Tower will light up from approximately 8:30 pm - 9:15pm. Members of the community can shine lights, at the tower, from various marked viewing sites. Volunteers in the tower will acknowledge by shining spotlights back to them. The other five Catskill Fire Towers, (Hunter Mt., Overlook Mt., Mt. Tremper, Balsam Lake Mt., and Esopus Valley will also take part in the state wide event. Come out and join us by shining a light at one of the fire towers. The rain date will be Sunday, Sept. 1, 2024.

Days of Yore... Today's History

September 15, 1954

Otto Hillig, 78, photographer and a veteran of one of the earliest single engine plane flights across the Atlantic, died Sept. 12, 1954 at Liberty Loomis Hospital. Mr. Hillig was born in Steinbruechen, Germany in 1876 and came to the United States when he was 16. In 1947 Mr. Hillig retired from business and in recent years he lived in the castle which he built long ago on top of Washington Mountain.

A daughter, Virginia Marie, was born to Mr. and Mrs. Elmer Everett Christiana Jr., of Cream Ridge, N.J. at Veterans Memorial Hospital on Sept. 3rd. Mrs. Christiana is the former Jean Sheeley of Lackawack.

Mr. and Mrs. Norman Eaton of Washington, Michigan announce the engagement of their daughter, Ann Clair, to Richard George Krom, son of Mr. and Mrs. George Krom of this village.

August 26, 1964

Mrs. Lula Kortright, 69, died suddenly at her home in Neversink on Sunday, August 23rd. She was married on August 24, 1944 at

Sundown to Earl Kortright. Mrs. Kortright was a member of the Neversink Fire Co. Ladies Auxiliary. She had made her home in Neversink for 20 years. Surviving are her husband; two sons; six daughters; seven stepsons. Also two sisters; two brothers; 48 grandchildren and one great-grandchild.

The first three winners in Senior Showmanship at a recent dairy show were Tri Valley FFA members. First for the second year in a row was Brian Mitteer, second was Eugene Slater and third was Ricky Strangeway.

September 4, 1974

Among the winners at the "Art in the Square Show" in Ellenville on Saturday, August 24th was Becky Brenner of Pepacton Hollow, Grahamsville. She won first prize in Sculpture in the professional category with her 3-D showing of "Ye Olde Colonel", an authentic replica of a Grahamsville neighbor. Although this is the first time Becky has entered her sculpture in Ellenville, she is no stranger to Sullivan County art exhibitions, winning prizes in shows in Monticello, Fallsburg, Hurleyville and our own Grahamsville Fair.

Michael Costigan, son of Mr. and Mrs. Robert Costigan, is at Central Connecticut State College on a partial athletic scholarship. He plans to major in Liberal Arts. Mike's brother, Philip, recently fulfilled his requirements for his Master's degree at Colgate University and will be teaching Spanish at Rye, N.Y.

September 6, 1984

Kate Gallagher, daughter of Mr. and Mrs. John Gallagher Sr. of South Hill, has been selected as a National Merit Scholarship Program semi-finalist. This program honors the outstanding high school seniors in all fifty states.

LOOKING BACK

Beatrice Akerley
Published August 5, 1998

Echoes from the past. It has been almost one hundred years since I heard the familiar "Bee, don't let that screen door slam again." My mother's voice. Our little seven room house of that time was bursting at the seams for a family of seven and my favorite relief valve was letting our screen door slam. I would then head for the grove and our lawn swing hammock and playhouse.

"Slap", the thin frame of the old screen door hit the side of the house on the backswing and "Bang" on its return trip. The wire mesh was much too thin and it seemed to bow out with the slightest pressure. The outward bubble that resulted was fun to push in and out and that caused the bubble to grow larger as it strained against the nails holding the screen to the frame. That always lead to a hole in the screen and the invasion of flies followed.

As we stood watching him replace the screen, I can hear him giving us kids a lecture on how the screen had to last at least a couple of summers if we went easy on it.

We were fortunate to have a spring on our front screen door and there was none on the one in the kitchen. It just sort of flopped back and forth, relying on some unseen force to hold it against the door frame.

Quite often as a child, I heard mother call out, "Who left the screen door open again?", and the sound of the fly swatter going "spat, spat" as mother showed no mercy on the flies.

In the good old days fly catchers did not hang from the ceiling. We bought them in sheets of sticky paper which we placed around the room. You had to watch where you sat or you'd be wearing one!!

Household Hint:

Don't Spend Hours Scrubbing Those Burned Pots and Pans

Burning our pots and pans because we got distracted during the course of cooking dinner is not abnormal and has happened to everyone at least once. We've all been there. In the past, if you have spent hours scrubbing away at the pan's burned bottom, this hit will put an end to that.

Just pour vinegar in the burned pot and boil. The vinegar will remove all those nasty burn marks, letting you get back to whatever pulled you away from the kitchen in the first place.

Nature Column - L. Comando

A tribute to the memory of all of the Townsman Ladies that we have loved so much and lost... Peggy DeWire, Avril Pappa, Joan Hall, Polly Hill, Joyce Lockhart, Jean Helthaler, Karen Curry, Barbara Slater, Shirley Davis, Hulda Vernooy and Carolyn Coombe.

Golden Carpets Covering the Catskills

It is that time of the year when the bright yellow blossoms of the beautiful Goldenrod carpet the landscape like a yellow rug.



There are over 135 species of Goldenrod (family Solidago) all native to the U.S. and most are found in the East. You can identify Goldenrod by two ways: The flower shape - plume, fountain, candle and flat topped. Flowers are clustered on long stalks. Most Goldenrods have long, narrow leaves. Some species' leaves have smooth edges and some are toothed.

Look at the basal leaves to tell what kind you've found. Goldenrods prefer open fields but have adapted to marshes, mountains, deserts and sandy beaches.

Goldenrod is a perennial plant that is well-known for its healing properties. This wild edible is a plant that reproduces through its roots, bulbs, stems and by its seed.

In many countries around the world, Goldenrod is used to treat disease. Native Americans applied a lotion made from goldenrod flowers to bee stings.

And like many other wild herbs, goldenrod has for centuries been the inspiration for legends and superstitions. According to one European tradition, goldenrod held in the hand will reveal hidden riches. Another claimed that the growing plant pointed to treasures of secret springs.

Sweet goldenrod, sometimes called blue mountain tea, has a rich history.

Long before the arrival of Europeans, the Native Americans recognized the value of its taste and they flavored other medicines with it.

After the Boston Tea Party in 1773, patriotic colonists devised a substitute for China tea called Liberty Tea, made from equal parts of sweet goldenrod, betony, red clover, and New Jersey tea (*Ceanothus americanus*). Later, sweet goldenrod became a cash crop in the United States. It was even exported to China, where it sold at high prices as a tea substitute.

Goldenrod is also a good choice for the novice dyer. It yields a strong, durable yellow.

Goldenrod does not cause seasonal allergies as many tend to believe. Why? For starters it is pollinated by insects. Only wind-pollinated plants such as Ragweed cause allergic reactions. Goldenrod gets blamed for hay fever because it blooms at the same time as ragweed, the real villain.

Bees, wasps, butterflies, moths, flies, and others visit for nectar and pollen. Caterpillars, aphids, and other small insects eat the leaves and stems. Wasps, spiders, praying mantis, lacewings, ambush bugs, assassin bugs, beetles, and birds prey on the insects Goldenrod attracts. There is even a Goldenrod Spider, who specializes in hiding on Goldenrod plants! Some insect predators, such as the Praying Mantis, lay their eggs on Goldenrod so their babies can feast on the little insects when they hatch.

All Goldenrods are late bloomers, flowering in late summer and into the fall. Goldenrod is considered a very desirable wildflower, because of the large number of spectacular yellow flowers that bloom in late summer and fall. Here in the Catskills we don't have to look very far to see its golden glow that brightens even a gloomy dark rainy late summer day.

Vintage 19th Century Base Ball Games at the Grahamsville Fairgrounds

(From Pg. 1) "More than likely, the players and the style of play will resemble what your great, or great-great grandparents would've seen over one-hundred fifty years ago."

The first game will be played by the rules and customs of base ball (spelled this way in the 1800s) in 1864. Fielders do not wear gloves, at all; gloves would not come around until the 1880's. The base balls are also stitched differently - often called a "lemon peel" - and made slightly larger than the modern "horseshoe" ball. And a batted ball caught on a "bound" or one bounce is an out. Of particular interest is that pitches are tossed underhand from a pitcher's box 45 feet from home plate - a round metal dish ten inches in diameter. Umpires do not call a ball or strike on the batter until they issue a warning: either to a pitcher for not serving up a hittable pitch, or to the batter for being too choosy with what to swing at.

The second game will be played by 1895 rules. "Base Ball in 1895 had subtle differences to the modern game. For example," states Miller, "the only balls landing in foul territory that are considered a strike on the batter are those that were bunted; they were referred to as a "foul strike". The gloves were quite different as well."

Admission is \$5 per person with children under 10 FREE. PLEASE BRING CHAIRS. Traditional base ball refreshments will be available for purchase at the concessions stand. For more information about this program, please call 845 985-7700 or email info@timeandthevalleymuseum.org.

About the Mountain Athletic Club: Founded in 1895 by yeast magnates Julius and Max Fleischmann, the Mountain Athletic Club draws its name from the field where many former major leaguers played before it was donated to the community in 1914. They are located in the present day Village of Fleischmanns in eastern Delaware County, NY. www.macvintagebaseball.org More about Mountain Athletic Club: From 1895 through the early 1900's, the young sons of famous yeast magnate Charles Flesichmann maintained a semi-professional ball club near their summer estate on the west end of the village of Griffin Corners (name was changed to Fleischmanns in 1914 following the donation of their private baseball park to the community). Over a dozen future and former major and minor league and collegiate players joined with brothers Julius and Max Fleischmann to form a power house of talent in the fledgling days of the Ulster and Delaware Railroad that enabled players from the many towns along the rail lines to meet throughout the summer. The current team was reborn in 2007 after over 100 years of dormancy through the efforts of Fleischmanns resident and player, Todd Pascarella. Following the floods of Hurricane Irene in 2011, the team went on hiatus and returned to form in 2017 and has been going strong ever since with at least a dozen or more games each season throughout the Northeast playing by the different rules and customs of the nineteenth century. In 2020, the M.A.C. Grounds at Fleischmanns Park were listed on the NYS and National Register of Historic Places to celebrate the 125th anniversary of the founding of the Club.

About the Connecticut Base Ball Club of Hartford: A tribute to the flurry of baseball teams that originated in the Greater Hartford area during the mid to late nineteenth century, the Connecticut Base Ball Club of Hartford also known as "The Hartfords" have been in operation since 2017 and bring a wealth of talent to the vintage game, having gone undefeated in 2023. [FB@ConnecticutHartfords](https://www.facebook.com/ConnecticutHartfords).

About the Time and the Valleys Museum: Connecting Water People and the Catskills, the Museum is open weekends Memorial Day to the end of September, noon to 4 p.m.. Located at 332 Main Street in Grahamsville (St. Rt. 55), Sullivan County, admission for adults is \$5, children under 16 \$2, and children under six are free.

All Museum exhibitions are interactive and both fun and educational for all ages:

- Water and the Valleys, an exhibit on the history of the Rondout and Neversink watershed area from early geological times to the 20th century. This exhibition includes interactives such as a Native American artifact guessing game, grinding corn with a mortar and pestle, videos and more.
- Tunnels, Toil and Trouble: New York City's Quest for Water and the Rondout-Neversink Story, an interactive exhibit on NYC water supply system and the towns that were removed to build the system, which includes computer interactives, games, puzzles, videos and building a dam and tunnel.
- 1930s Lost Catskill Farm, a farmhouse, outhouse, barn, electric plant, milk house and working waterwheel help visitors experience life in the 1930s through displays, videos, games and hands on activities, including the new exhibition As the Wheel Turns: Water Powered Industries in the Catskills.
- Bittersweet Memories: Lost Towns of the Catskill Watersheds a collaborative augmented reality art exhibition of the buildings and homes taken for NYC's water system.

The Time and the Valleys Museum is proud to be a Blue Star Museum, a collaboration between the National Endowment of the Arts, Blue Star Families, the Department of Defense and over 1,500 museums across America to provide free admission to active duty military members (with ID) and up to five family members. This free admission for members of the military and their families runs from Memorial Day to Labor Day.

For more information call 845 985-7700, e-mail info@timeandthevalleymuseum.org or visit www.timeandthevalleymuseum.org. To schedule a group tour for



Photo by Collin Miller

Hamden – Mountain Athletic Club, 2024

Dwight Coombe –Citizen of the Year (From Pg. 1)



Dwight honoring our Vietnam Veterans

During his insurance career, Dwight has obtained the professional designations of Certified Insurance Counselor and Certified Commercial Risk Manager. Through the years, he has served on several insurance company advisory boards and helped automate the agency. Dwight is presiding officer of DCS Risk Management Solutions, LLC, comprised of insurance firms who collaborate, share knowledge, and build stronger relationships with insurance carriers, for the good of their clients.

Dwight has worked with the Noonday Club for decades on many projects, including working at the senior citizen holiday dinner and putting up and taking down the holiday ornaments on the electric poles throughout Ellenville. He served as officer positions for the Noonday Club through the years as well as for the Ellenville-Wawarsing Chamber of Commerce. He also negotiated and coordinated the borrowing of the original Boy with Boot statue, to have local artist Matt Pazorsky, cast the bronze statue that has been seen in Ellenville's Liberty Square for many years now.

The aviation industry is a passion of Dwight's. Earning both private and commercial pilot licenses with instrument rating, Dwight has acted as an advisor for the Town of Wawarsing board through at least five supervisor administrations regarding airport matters at the Joseph Y Resnick Airport. During this time, they have brought in federal and state money to rebuild the runway, taxiway, landing lights, and install fencing and fuel service.

Dwight helped organize and fly the Young Eagles program for the town of Wawarsing area, where young people were introduced to flight through a 15-20 minute ride, and then gained knowledge about careers to consider that involve the aviation industry.

Besides using his pilot's license to conduct business in various states and distant locations, Dwight also volunteers to fly for Patient Airlift Services (PALS), sometimes with missions twice a week for months. This organization helps transport patients who require special medical treatments.

Since about 2008, Dwight has served as the president of the Greater Wawarsing Local Development Corporation. He and the other volunteer board members manage funds that are available to new and existing businesses in the township, to borrow, to aid in developing and/or enhancing their businesses. The board's efforts have included the HealthMatch program that has helped attract and commit new medical professionals to the area served by the Ellenville Hospital.

In 2015, Dwight and his staff at Sprague & Killeen, Inc. started Wings & Wheels for Warriors, a car, truck, motorcycle, jeep, tractor, and airplane show held at the Joseph Y Resnick Airport each year, on Armed Forces Day in May. This event was established to give back to the community that has supported them for many years, as well as raise money for a worthy cause. With the help of his staff and the many volunteers, Dwight and Sprague & Killeen, Inc. has raised over \$157,000 to date, for the Disabled American Veterans (DAV) of New York. This is an annual event that grows every year, dedicated to the cause. Dwight makes certain every penny raised from the event, goes to the Disabled American Veterans of New York. Sprague & Killeen, Inc. covers all expenses. It is an exciting day for the community! Thousands of spectators have attended the show, featuring as many as 210 vehicles in a given year. Mark your calendars, the 10th annual Wings & Wheels for Warriors is scheduled for May 17, 2025. Dwight and his staff hope even more people decide to get involved, as participants, volunteers, or simply to enjoy the day's activities.

Dwight Coombe is passionate about many things. Expanding knowledge, finding and developing opportunities, and helping others is always at the forefront. Congratulations to Dwight for earning the recognition as this year's Ellenville Noonday Club Citizen of the Year, a well-deserved honor! Anyone wishing to celebrate with him at the dinner on September 21st should contact Mary Sheeley of the Noonday Club at (845)647-8100. Cost of dinner is \$65/person and will be held at the Soyuzivka Ukraine Heritage Center in Kerhonkson. Reservations must be made, and payment received in advance of attending the dinner.

Claryville Reformed Church will be celebrating its 175th Anniversary!

On September 8th the Claryville Reformed Church will be celebrating its 175th Anniversary! We invite the community to join us that afternoon from 1-3 for birthday cake and ice cream in our fellowship hall. Our church and the schoolhouse museum will also be open for visitors.

On September 12, 1849, Rev. I.C. Duryee and Elder Austin Strong, both of Woodbourne, and Rev. L.B. Ayers of Ellenville, representing the Classis of Orange, held a meeting in the school house. Following proper notice, this was held for the purpose of forming a Reformed Protestant Dutch Church.

Conrad Crum, Sara Crum, Isaiah Hall, Elsey Hall, James Donalson, Clarisa Donalson, Josias Dixholm, Sarah Dixhom, James Lamaten, Elizabeth Lamaten were received as members on confession of their faith. Issac VanAken, Mary VanAken, Marichus Weist, Agnes Weist, Jane H. Many, Polly VanAken, Margaret VanAken and Margaret Donalson were received as members on Certificate from the Grahamsville Church. On November 8th, Rev. Duryee preached a sermon in the school house and administered what was probably the first communion service for the new church group.

During the following years, the church had as many as 100 in the congregation. But after the tanneries closed, many families left the community. The church has experienced both good and difficult times over the past 175 years but we are thankfully celebrating all those who kept this fellowship alive. We gather each Sunday at 10:15 for morning worship and our Sunday School meets at 9:30. Visitors are always welcome!

Just in case you're wondering, we'll be re-running some of our best and most popular book reviews. They will be described as our *Legacy Mysterious Book Reports*. Send us a quick request if you have a favorite that you'd like to see again and we'll do our best to re-publish it.



The Bone Hunger

Legacy Mysterious Book Report No. 97

by John Dwaine McKenna

Mysterious Book Report No. 415
Published August 27, 2020

All novelists are bright. That's because writing is a craft that demands much, and promises nothing more than thousands of hours of solitary and challenging work, putting together what we hope will be a story with an engaging plot, interesting characters and a few surprises along the way that will entertain and involve our readers, maybe even get them back for more of the same character. *It's a tough row to hoe*, as my old granny used to say . . . but that, I think is what gives writing its allure. It's hard to do well. Damned hard.

Then, along comes a writer with such talent that she makes the near-impossible look easy . . . which is a mark of genius. Her name is Carrie Rubin. She's a physician-turned author, whose newest, *The Bone Hunger*, (Indigo Dot Press, \$25.99, 305 pages, ISBN 978-1-7328541-4-7) is a genre-bending medical thriller, murder mystery and paranormal hair-raiser, all rolled into one. It features a second year orthopedic surgery resident named Benjamin Oris, who's the star pupil on a knee and hip replacement team under the tutelage of the illustrious Dr. Kent Lock, at Philadelphia's Montgomery Hospital.

The novel – and the trouble – begins when Ben discovers the severed leg of one of his former patients while out for a run in the park. Not only is the leg severed, it shows bite marks, a roadrunner tattoo . . . and the surgical implant Dr. Oris helped install just two weeks earlier. But the patient, who hadn't been following orders to exercise, had died in front of Ben from a blood clot in one of his lungs. The police, the hospital administration, and the surgical team all question Dr. Oris, who's had some problems in the past. Then, more body parts start showing up . . . and the killings and mutilations become more frequent . . . while the tension and suspense ratchets up with every page. Each new revelation deepens the mystery and enlarges the suspect pool in this complex medical thriller. It will leave you feeling as if you're ready to scrub in for the next orthopedic surgery with the same team that recently survived a plane crash in wintertime in Alaska, and five days without food, while on a humanitarian mission. *The Bone Hunger* has more twists and turns than the Iditarod Race. It'll keep you guessing until the end and hollering for more from Carrie Rubin, a woman with a special gift for writing and a serial character you'll admire, if not love, named Dr. Ben Oris!



Like the review? Let your friends know, *You saw it in the Mysterious Book Report*, because the greatest compliment you can give is to share our work with others.

And Hey! Check out our combined website that's simple to use and easy as pie to leave your comments! We're looking forward to hearing from all of you.

<http://Johndwainemckenna.com>

or

<http://Mysteriousbookreport.com>

Thank You!

John Dwaine McKenna's Books
are now available at the
NEVERSINK GENERAL STORE



The Skin Ripper
A Jake McKenna novel
John Dwaine McKenna



The NEVERSINK CHRONICLES
The art of John Dwaine McKenna



JOHN DWAINEMCKENNA
UNFORSAKEN



The Whim-Wham Man
John Dwaine McKenna



Colorado Noir
Stories from the 1930s and 40s
John Dwaine McKenna



The Olive Jar

by Carol Olsen LaMonda Summer's Demise

Even though I have been retired for nineteen years now, the end of August will always be a demarkation of the end of summer. Perhaps, it is because the month of September was always a clean slate, a new page with new students and

a new beginning. Summer's end was the end of vacation and the beginning of a new work year.

It is at this calendar moment that I would begin to feel guilt for all the unfinished summer projects on hold until next year, regret that the hours of sunlight were waning, and feeling that the summer had, once again, gone by at warp speed. Perhaps that is why I always took note of the signs that summer was coming to a close.

Here are my sure signs that, even though there may be many warm sunny days ahead, summer is in the throes of its annual demise:

The katydids sing me to sleep

I begin to have those "teacher dreams" where students are unruly. I am late, lost and cannot find my schedule.

Labor Day signals the Town Pool closing and ushers in Olive Day for the following Saturday.

People are wearing sweatshirts for the morning and night chill.

There are chicken barbecues planned as if no one would eat chicken on the grill ever again.

Pumpkins and mums replace peaches and geraniums at roadside stands.

Football and political ads proliferate on the television.

Advertising features backpacks and school supplies.

Like the grasshopper and the ant, I am still in frivolous grasshopper mood, but I know that I need to savor September before I have to become an industrious little ant gathering wood, bringing in houseplants before the frost, and shutting windows against the cold night air.

The FamilyMemoir, PROSILIO...

... in Greek means "Toward the Sun," was written by Carol Olsen LaMonda. Carol writes the column "The Olive Jar" for *Ye Olde Tri-Valley Townsman*. This local author has been busy guesting at book clubs who have chosen this local memoir as their book choice. **Feel the warmth of "Prosilio" as you read Carol's memoirs cuddled up in your favorite chair. It also makes a great gift!** *Prosilio* is available at Amazon or Barnes and Noble on-line as a soft or hard cover or as a downloadable e-book for Nook or Kindle. Go to: <http://amazon.com> or <http://barnesandnoble.com> and type in *Prosilio* in the search to order your copy of *Prosilio*

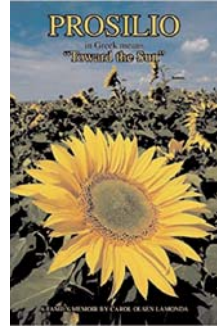

Olive Day
September 7, 2024

Come and join us for a fun filled day

Live Music
Spillway Band / Night Train

5K Run Car Show
Frog Jump Cornhole Tournament

Vendors, Food, Games & Bouncy Houses!

for more info visit the Olive Day Facebook page

Car Show
Olive Day
September 7, 2024

Watson Hollow Rd.
Davis Park
West Shokan

Saugerties Corvette Car Club

We would love to have your car at our car show... any year, make or model!

10am - 2pm

COME & VOTE FOR YOUR FAVORITE CAR!!

All proceeds to benefit Olivebridge Methodist Church Food Pantry
for more information contact
Debbie Downes at 845-417-8149 or 1963downes@gmail.com

BOB Competition a Blast!

Summer Reading Challenge Deadline August 31, Fall Children's Programs Gear Up

By Lisa Carroll

GRAHAMSVILLE-While we didn't place at the 2024 Battle of the Books competition this past Sunday at SUNY Orange, we couldn't be more proud of our girls, the "Country Pumpkins," for giving it their best and they did have a great time!

The team, consisting of soon-to-be ninth graders Shelby Carroll, Ava Bush, and Abby Rusin and eighth grader, Samantha Carroll, were led by TVCS secondary school teachers Matt Haynes and Jessica Dymond. They stared down a pile of novels at the beginning of summer (eight to be exact), read them, digested them and discussed them...for their determination, they were victorious. And it has to be said, as the library liaison for the team (and as a mom), it takes guts for these teenagers to face off against so many other teams, in front of an audience and under timed conditions. So, did they win? No, they did not. But did they show up to weekly practices all summer? Did they read an astounding number of books? Did they then climb the stairs to sit upon the stage in front of teens and adults to be tested on the knowledge derived from those books? Absolutely!

Truth be told, they weren't terribly broken up about not winning either. As they put it, if they didn't win-someone else would. With so many teams there, each one giving it their all, it's really hard to feel upset about our outcome. As a library employee (and avid reader) I can't very well look around a room of nearly 100 teenage readers and come away feeling sad, now can I? It's such an uphill battle getting teens to read, with so many other things competing for their attention, that I call the BOB competition in its entirety a win.

And, next summer, perhaps more of our Tri-Valley secondary students would like to join the team and give it a go. It's a fantastic way to read some great books (possibly out of your typical genre), meet some new friends, (and be a part of something that will really stand out on those college applications, just saying!)

In other news:

Our summer reading challenge is coming to an end August 31, so please turn in your (or your children's) completed reading logs or bingo sheets to collect your prizes. Announcement of our adult and young adult winners, as well as, specific numbers of challenge participants will be forthcoming.

With summer wrapping up, we are in full swing preparing for our eight-week Fall Children's Programs, beginning the week of October 14. For complete details and to register please visit our website. We are also busy getting ready for our Giant Pumpkin Party on Saturday, October 5. For that, we are still accepting donations of gently used books, so if you have any you are willing to part with please speak with Michelle Gorman at 845/985-7233. Also, we are seeking volunteers (adults and teens) to help out at the Giant Pumpkin Party, as well as, at the library during regular



BLOOMING GREEN LAWN AND LANDSCAPE SERVICE

Ben Knight

845-985-0516 • 845-665-3348

Fall Cleanups

Book Your Landscaping Jobs Now!

Trees, Shrubs, Perennials Planted

Pruning

• Shrubs • Fruit Trees • Ornamental Trees
Custom Complete Lawn Care • Edging
Raised Flowerbeds • Mulching • Light Landscaping

**Over 25 years experience
Residential and Commercial**

Fully Insured

Firewood

Buy from the best

Don't be undercut by the rest

Check out our website:

<http://www.bloominggreenlawnandlandscape.com>

"If it grows by day, have it cut & split by Knight"

business hours and for special programs, so if you are interested please fill out an application (found on our website) and turn it in at the adult circulation desk.

On a final note, I did this thing. So, I was fascinated by the A to Z reading challenge I saw on Facebook, so I decided to give it a try. From September 1 of 2023 through 2024, I recorded every book I read with the intention of filling the alphabet. This year, I read a total of 42 books. I missed a few letters and read multiple books with the same starting letter, but all in all, I feel pretty good about my list.

Along the way I learned some interesting things. The first, Christina Lauren, author of Love and Other Words as well as The Unhoneymooners-both great books-is actually two best friends who co-write. Second, I loved the Riley Thorn series by Lucy Score, of which I read the first three in the series. If you are looking for a bit of spice, chaos and humor, this is the series for you! And third, I stand by the philosophy that books are better than their movie counterparts. I read The Sun is Also a Star, an amazing YA book by Nicola Yoon and the adult fiction novel, The Mountain Between Us by Charle Martin, which was also fantastic and then tried watching the movie versions. Let me tell you, I spent a lot of time comparing the books to the movies and they (the movies) just didn't measure up.

I'm planning on completing the challenge again this fall (hopefully, getting a book for each of the 26 letters this time, but who knows) so, if you decide to start such a challenge yourself this fall, I will gladly give you recommendations and would be interested in seeing your own completed list next fall.



FRESH

NEVERSINK GENERAL STORE

Now Serving Italian Meals
Cooked to Order Daily

GET YOUR CREEPY

**Chicken Parm w Pasta
Eggplant Parm w Pasta
Fresh House Made Marinara**

845-985-2076

<https://neversinkgeneralstore.com>

Cruise through summer with peace of mind.
Knowing **Sprague & Killeen, Inc.** has all
your insurance needs covered.



116 Canal Street, Ellenville, NY

Call us today at 845-647-9100 for a quote!

TRUSTED LOCAL AGENCY SINCE 1867

The Scene Too

By Jane Harrison
No Column this week.

First American Female Soldier Deborah Sampson Fights a REVOLUTION!

History At Play's Critically Acclaimed Immersive Experience Travels to Narrowsburg, NY

An Event at Fort Delaware Museum of Colonial History sponsored by Bold Gold Media, the Upper Delaware Scenic Byway, and Foster Supply Hospitality.

Saturday, August 31, 2024 at 3 p.m.



Photo Courtesy
History At
Play/Vincent Morreale
Photography

J. Kalaora as Deborah Sampson.

NARROWSBURG, NY-- The Bold Gold Media Speaker Series continues at Fort Delaware Museum of Colonial History on Saturday, August 31 with an internationally acclaimed presentation of “A Revolution of Her Own” the story of the female Revolutionary War soldier, Deborah Sampson.

History At Play™, LLC has garnered international applause for their Immersive Living History Experiences, chronicling the lives of influential and often forgotten figures. “A Revolution of Her Own!™” is the awe-inspiring story of America's first professional female soldier, Deborah Sampson.

The program has been performed nearly 2,000 times in venues across the nation, as well as virtually around the globe. Receiving accolades from journalists, historians, and educators alike, the production earned the honor to be an Official Selection for the United Solo Theatre Festival in New York City. Now, Deborah Sampson travels to Narrowsburg, NY to tell her incredible story at Fort Delaware Museum, on Saturday, August 31, at 3 p.m. This is an exclusive event sponsored by Bold Gold Media, the Upper Delaware Scenic Byway, and Foster Supply Hospitality. Running time for the program is approxi-

mately 60 minutes, plus a Q&A following the performance. The program is included in the price of admission to the Fort that day, and all tours at the Fort will end at 3 p.m. so the program can begin.

“A Revolution of Her Own!™” features History At Play™, LLC's (HAP, LLC) Founder and Artistic Director Judith Kalaora in an immersive solo performance as Deborah Sampson, the first woman to successfully enlist, to professionally fight in, and to be honorably discharged from the American Military. The hour-long program chronicles her life: An indentured servant by age five, Deborah grew up in a man's world, where women were naught but second-class subjects. Without the ability to vote nor own property, Deborah knew options were limited; breaking the rules may be necessary to accomplish a greater goal in life. Experience Deborah's arduous upbringing, one and a half years of active combat, and success as America's first professional female soldier, through interactive stories and authentic colonial attire. Deborah's passion will take you back in time! Program includes simulated violence. Viewer discretion advised. Rated PG.

Featured in news media outlets, including WCVB Boston, CBS WBZ Radio, The Associated Press, and The New York Times, HAP, LLC's Artistic Director and Founder J. Kalaora has expressed the delight and difficulty in portraying America's first professional female soldier. Jordan Rich of CBS WBZ News Radio states, “She's a one-woman force of nature and inhabits these women...it takes people like Judith to bring these stories to life...these lost pieces of history.” The Associated Press described Kalaora as “drawn to characters who seem conflicted about society's gender roles...Kalaora not only portrays these women on stage, she emulates them in life, starting her own company to portray and educate about 'influential, but oft forgotten women.’”

About History At Play™: Kalaora established History At Play™, LLC in 2010 to create enriching historical entertainment. Kalaora is a resident of Massachusetts and a Magna cum Laude graduate of Syracuse University and Shakespeare's Globe Education Program of London, England. Kalaora has performed on international stages from London to Montreal, as well as venues across the United States. History At Play™, LLC performs their expansive repertoire virtually, in-person, and via hybrid format to audiences around the globe. For information, HistoryAtPlay.com.

About Fort Delaware Museum: Fort Delaware is located on the Upper Delaware Scenic Byway at 6615 Route 97 in Narrowsburg, NY. It is open from 10 a.m. to 5 p.m. Thursday thru Sunday until Labor Day (and the holiday) and Saturdays and Sundays in September and October. It is owned by Sullivan County and operated by the Barryville based non-profit history education group, The Delaware Company. Visit thedelaware-company.org for more information.

SCDW 10 Minute Play Festival

Short attention span? Difficulty in choosing what to see? No problem! The Sullivan County Dramatic Workshop is excited to present a new version of an old favorite: The 10 Minute Play Festival - a showcase of short (10 Minute) masterpieces to entertain you. Each of the two programs consists of six plays - a variety of comedy and drama. It's a mighty mix of laughter and tears.

Produced and directed by Amber Schmidt and Lourdesa Hunt, this season's 10 Minute Play Festival brings you two weekends of fabulous original plays written by playwrights local and beyond. Local directors Sally Gladden, Lourdesa Hunt, Joshua Patriarco, Anna Puleo, Amber Schmidt Grace Summa and Harold Tighe offer their expertise in presenting an entire play in 10 minutes!

Come see six plays on Friday and Sunday; and/or treat yourself to all 12 plays on Festival Saturdays with the bonus of an intermezzo with food and entertainment.

All performances are at the historic Rivoli Theatre in South Fallsburg. Performances are Fridays, 9/13 & 9/20 at 8:00PM, Sundays, 9/15 & 9/22 at 2:00PM, and Saturdays at 4:00PM and 8:00PM - or Festival tickets include both performances plus refreshments. Tickets for each set of 6 plays are General admission \$15 (plus fees on-line), seniors/students/military \$12 (plus fees on-line). Tickets for both sets and intermezzo-Festival Saturdays \$22 (plus fees on-line). For more information, www.scdw.net.

Wayne County Arts Alliance Art Auction

WCAA is excited to announce that the online auction begins September 4 for our "Garden Art Totems - Horti-Sculpture" 2024 Summer Outdoor Art Project. Which of the 35 Totems will you bid on? This online auction is only for a limited time: September 4th - September 19th <https://new.biddingowl.com/WCAAGardenArtTotems>

All summer long the Garden Art Totems have been seen and enjoyed by everyone in our community and county. NOW, you have the opportunity to own your favorite Totem for your own garden or porch, or display wherever you wish.

Each totem is unique and was designed and created by a local artist. Your purchase will help support the Wayne County Arts Alliance and its ongoing projects. Winning bidders will be contacted following the end date of the auction, September 19th, to coordinate pick-up of their Garden Art Totem.

The "Garden Art Totems" project was organized by WCAA Artist Member Nadine Kloss-Gannon. Local businesses and friends sponsored the Totems in 35 locations all over Wayne County from Memorial Day through Labor Day. View the map and details about Artists and Sponsors at waynecountyartsalliance.org/summer-art-2024/

Wayne County Arts Alliance is a not-for-profit organization governed by volunteer members - artists and persons interested in the beneficial effects of the arts. WCAA is committed to developing a dynamic, art-friendly atmosphere in the community, one that enhances and enriches the lives of its citizens. For more information visit: www.waynecountyartsalliance.org

We thank each and every bidder for supporting WCAA and our many art projects.

Link to auction -

<https://new.biddingowl.com/WCAAGardenArtTotems>



First Class Formalwear

**Tuxedo's & Suits
Gown Alterations
Gown Preservation
Wedding Invitations**

Rentals & Sales

311 East Broadway • Monticello, NY 12701
(845) 796-1039
www.firstclassformalwear.com



T. Halpin Mechanical Corp. DBA
Ert's Mechanical

Plumbing – Heating – Air Conditioning

845-292-4571

Liberty, NY



Creating your own art is a form of meditation and a therapy unique to your own self. *In the Spirit of Sumi-e*, written and illustrated by Linda G. Comando, is an easily understood explanation including simplified drawings that will lead you on a path of relaxation and will reveal your own potentiality and creativity.

Now available on Amazon:
Go to: Amazon.com
then type in *In the Spirit of Sumi-e*

IT CAN HAPPEN TO ANYONE

24/7 LOCAL ADDICTION INFO & REFERRAL

866-832-5575



NATIONAL:
TEXT #HOPENY



Town of Olive joins the Images of America Series

(West Shokan, NY) On Monday, September 2, 2024, Town of Olive will join Arcadia Publishing's Images of America series-authored by Melissa McHugh, director and archivist at the Olive Free Library, with a foreword by Town of Olive artist Kate McGloughlin.

The Town of Olive has long been a sought-after place known for its beauty and natural resources. From the late 1600s, pioneers explored the area and established homes in the majestic Blue Hills and along the Esopus River. These early pioneers made a living in agriculture, tanneries, and mills. Later, when visitors wanted to escape the heat of New York City, residents hosted boarders, and a booming industry was born. The community drastically changed in the early 1900s, when New York City came not just to visit but to look for a new source of water.



Olive earned a living and spent their time and leisure through the years.

McHugh-an educator, businesswoman, archivist, and the director for the Olive Free Library in West Shokan, NY-tells the story of the Town of Olive through photographs, many of which are from her curated exhibit at the Olive Free Library about the history of the Ashokan Reservoir. She answered a few questions in anticipation of the September 2, 2024 publication of Town of Olive:

When did you realize you were going to do this book project?

I was with my brother Mike, a big history buff, at Barnes & Noble and he was looking through the local Arcadia Publishing books and he asked me why Olive didn't have one. I had just finished curating the Town of Olive Bicentennial Exhibit through which I had met so many wonderful people. I learned so much about the Town's history and their own family stories that I realized I really wanted to write this book.

What was the most surprising thing you learned in the course of your research for this book?

It continuously surprises me what a robust history the Town has that doesn't even include the Ashokan Reservoir. Bluestone quarried here in Olive was used to create sidewalks in New York City, there were 82 boarding houses in 1906 accommodating approximately 2,492 tourists, not including families who rented out a single room or two, and the local tanneries supplied the Union Army with leather during the Civil War.

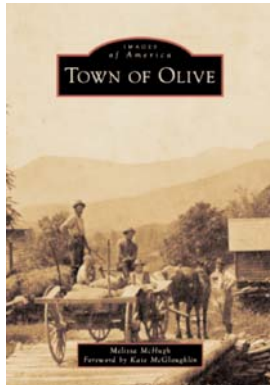

•Pools Sold •Liners Sold •Filters Sold

WOODIES CONSTRUCTION

ABOVE GROUND POOLS

*Installations • Repairs
Liners Sold & Installed*

845-985-2003 • 845-943-0024

Pools Installed **Pool Take Down & Take Away**

Liners Installed

Filters Installed **Opening, Closing & Repair**

**Bought your pool/liner ON-Line
Call Us to Install It**

Can you say a couple things about your process of putting it all together in this format?

Arcadia Publishing has a strict format they adhere to in formatting the book. In some instances there were some great images, but trying to find a place for them within the narrative was difficult. What do you hope this book does out in the world? Who do you hope it finds?

I hope the book provides a small glimpse into our Town's history and creates interest in learning more. Here at the Olive Free Library, we have a wonderful local history area, museum, and archive, where I did most of my research. I hope the people of Olive smile when they see the book out in the world, already knowing what a wonderful Town we have! I hope visitors and newcomers to the area take an interest not only in Olive as it is now, but also in its beginnings and the resiliency of its people.

McHugh will be at Olive Day on Saturday, September 7 at Davis Park, West Shokan, NY, where she will have copies of the book for sale. The following Saturday, September 14, she'll be at Tetta's Market at 2082 County Road 3, Olivebridge, NY for a book signing at 1:00 p.m. And on Saturday, September 28th McHugh will do a book signing at Barnes & Noble in Kingston, NY.

You can also find Town of Olive at Woodstock's Golden Notebook, Barnes and Noble, and Amazon.

The Images of America series celebrates the history of neighborhoods, towns, and cities across the country. Using archival photographs, each title presents the distinctive stories from the past that shape the character of the community today. Arcadia is proud to play a part in the preservation of local heritage, making history available to all.

DENMAN CONSTRUCTION

Builders of Fine Custom Frame & Log Homes

- Additions & Renovations
- Heavy Equipment Work
- Septic Systems
- Drainage Work
- Stone Work
- Fireplaces
- Flood Damage Repair



- General Carpentry
- Interior & Exterior
- Painting & Staining
- Tile Work
- Wood Floors
- Driveways
- Road Building



We Build the American Dream
Poured Concrete Foundations
Complete Site Work



Rick (845) 985-2212 DEC Approved Flood Control Contractor **Jim (845) 647-4059**
denmanco@hvc.rr.com



JAMES'

General Store

Save time... Main Street • Napanoch
Call your order in! **647-5973**

Open 7 Days • 6 AM to 7 PM
• Breakfast 6 am- 11 am

- Coffee
- Cappuccino
- Hot Chocolate
- Lunch Specials
- Deli Sandwiches
- Hot Sandwiches
- DVD Rentals

ATM Machine

Fully Insured

Free Estimates

DEAN CONSTRUCTION & HOME IMPROVEMENT CORP.

We provide professional installation of
Roofing, Siding, Windows, Doors,
Decks, Seamless Gutters and so much more

(845) 985-2398



SHEELEY OIL & EXCAVATING INC

- Driveways
- Septics
- Excavating & Bulldozing

P. O. Box 255
Claryville, NY 12725
PHONE: 845-985-2231
FAX: 845-985-0186

- Fuel Oil
- Kerosene
- Budget & Pre Pay Plans

Email: suesheeley@gmail.com
<http://www.sheeleyexcavating.com>



David Trestyn

General Contractor

PLUMBING HEATING WATER PUMPS

845-321-1919
845-985-2731

PO BOX 359
Grahamsville, NY 12740
davidtrestyn@yahoo.com



RACK CONSTRUCTION

Get the Best Deal for Your Buck!

If you are in a Rut, We'll Help You with Your Doe!

- Siding
- Flooring
- Additions
- Painting
- Sheetrock
- Deck Gazebos
- Interior/Exterior Renovations
- Basement & Attic Remodeling
- Managing & Cleaning B&B's



Free Estimates • Fully Insured

347-719-1396



Studio Artists Group

at the Daniel Pierce Library
Wednesdays from 9:30 - 12:30
Come paint with us!

Join this collaborative group as we create and inspire each other. Please bring any art supplies that you plan to work with to create your piece. Adults only.

Daniel Pierce Library

1st Friday BOOK CLUB

The first Friday of every month.

All adults welcome!



Hats off to All the Workers -L. Comando

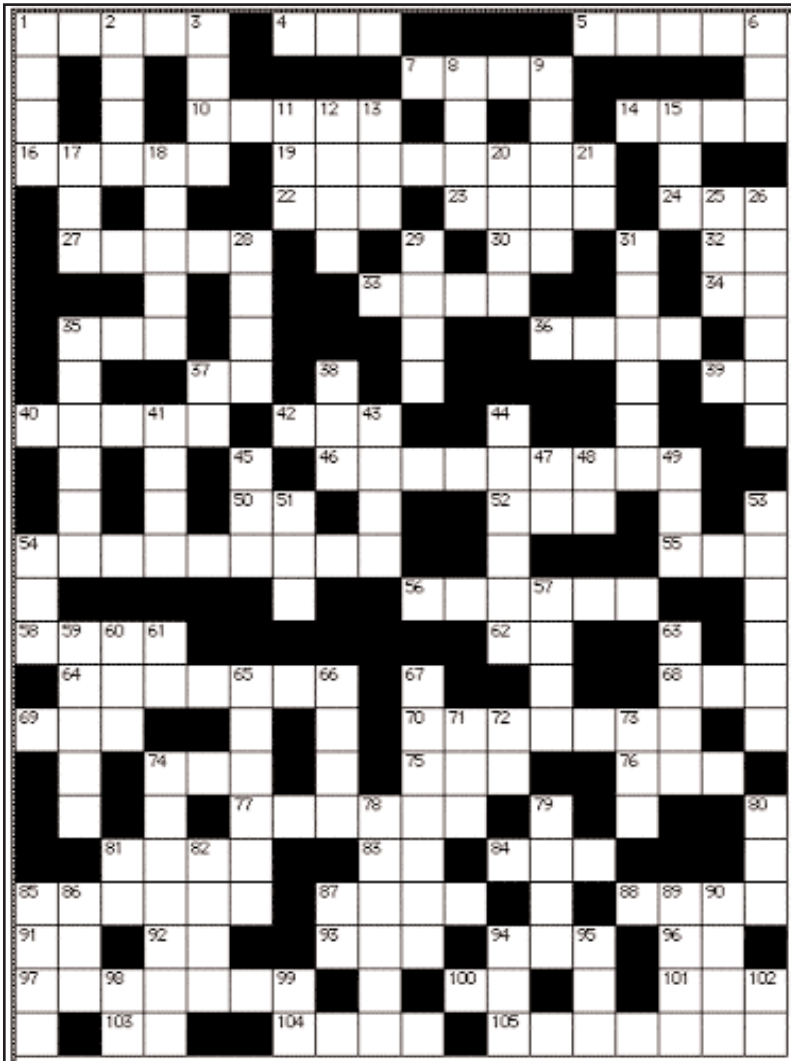

- 31 Flat surfaces
- 35 Organized Workers' form of protest
- 37 Indefinite article
- 38 Possesses
- 41 Land measure
- 43 Pillar or post
- 44 Woven container
- 45 Evergreen
- 47 Long Island
- 48 Enclosed
- 49 Hot brewed beverage
- 51 Expressing permission
- 53 Educational institution
- 54 Portable bed
- 57 Docile
- 59 Conscious
- 60 Mire
- 61 Senior
- 63 Prophetess
- 65 Ballerina
- 66 Shout
- 67 Day of festivity
- 71 Popular pen brand name
- 72 South Dakota
- 73 Contend
- 74 Type of drugs used to reduce levels of fat in blood
- 78 Outer parts of tires

- 79 Brown carbonated drink
- 80 A generation
- 81 Saint
- 82 Breakfast, lunch or dinner
- 85 Elegant
- 86 Cereal plant
- 87 Railroad
- 89 Capital of

- Norway
- 90 Fermented drink popular in NYS
- 94 Persuade
- 95 Line
- 98 Exist
- 99 "___ Olde Tri-Valley Townsman"
- 102 All right

Elote - Mexican Grilled Corn

- 6 ears of corn, shucked and fibers removed
- 2 tsp mayonaise
- 3 tsp sour cream
- 1/2 cup grated or shredded parmesan cheese, or you can use a Mexican cheese called Cotija
- 1 tsp chili powder
- 1/2 tsp salt
- 1/8 tsp black pepper
- 1/4 cup cilantro, chopped
- 1 lime, cut into 6 wedges

Heat grill over medium heat and spray rack with non-stick cooking spray. Grill corn, turning frequently (so they don't burn), until the corn is slightly browned and heated through. (about 8-10 minutes)

Meanwhile combine the mayo and sour cream in a small bowl and whisk until smooth.

In another small bowl combine the chili powder, salt and pepper.

Slather the hot grilled corn with mayo/sour cream mixture using a pastry brush to brush it on. Then sprinkle with the chili powder mixture. Coat in the parmesan cheese, and sprinkle with the chopped cilantro.

Serve with a lime wedge that will be squeezez all over the cobs.

数字は単数に限る

	4			6		3
7					6	9
	5		3	9		
3			5	6	2	8
		8	7		3	4
		1	4	8	9	5
				2	8	4
9		7				2
	3		6			1

- ACROSS**
- 1 Hard physical work
- 4 Between sunrise and sunset
- 5 Merging
- 7 Hobble
- 10 Medieval Scandinavians
- 14 Second-hand
- 16 Gratifying; self-respect
- 19 Avoiding waste
- 22 Adult human male
- 23 Solitary
- 24 Regulation
- 27 Scheme
- 30 Nearby
- 32 Exclamation of awe

- 33 Violent disturbance of peace by a crowd
- 34 Emergency Room
- 35 Legume commonly used for replacement of animal protein
- 36 Bird wing movement
- 37 Chem Element
- 39 People in general
- 40 Biological part
- 42 Circulating fluid in the vascular system of plants
- 46 Anti-corporate; Progressive
- 50 I am
- 52 Immoral

- act
- 54 Praise publicly
- 55 Curve
- 56 Rough drawing
- 58 Restaurant bills
- 62 Brit's thank you
- 64 Day in which one works
- 68 Self-esteem
- 69 Purse
- 70 To see
- 74 Central body of the solar system
- 75 Cap
- 76 Anger
- 77 Relating to the Celts
- 81 Like
- 83 Road
- 84 Occupation
- 85 Pottery maker
- 87 Peruse

- 88 Part of the ear
- 91 Overeaters'
- Anonymous
- 92 Iowa
- 93 Beam of light
- 94 Auto
- 96 Southeast
- 97 Welsh explorer who found Dr. Livingstone
- 100 Not any
- 101 August sun sign
- 103 Title used for a woman before her surname
- 104 Where the sun rises
- 105 City where the first Labor Day holiday was celebrated (2 wds)

- DOWN**
- 1 Live Action Role Playing
- 2 Knife used in the Philippines
- 3 Russian female who developed the philosophy of "objectivism"
- 6 Bow
- 8 Graven image
- 9 Send to press
- 11 Rapid Eye Movement
- 12 Person who refuses to join a union
- 13 Long period of time
- 15 Sun
- 17 Despicable character
- 18 Harmony
- 20 Water-filled ditch surrounding a castle
- 21 Common Era
- 25 Bitter beer
- 26 Laborer
- 28 Monarch
- 29 Money reward

Answer on page 23

To play SUDOKO online:
<https://sudoko.com>

Cryptogram

A	B	C	D	E	F	G	H	I	J	K	L	M	N	O	P	Q	R	S	T	U	V	W	X	Y	Z

Kids' Labor Day Fun Page

- L. Comando

19 25 11 2 11 10 26 10 11 24 20 11 26 24 4 9 12 6
 22 12 14 14 11 22 22 19 21 9 10 7 11 26 8 9 10 19 6

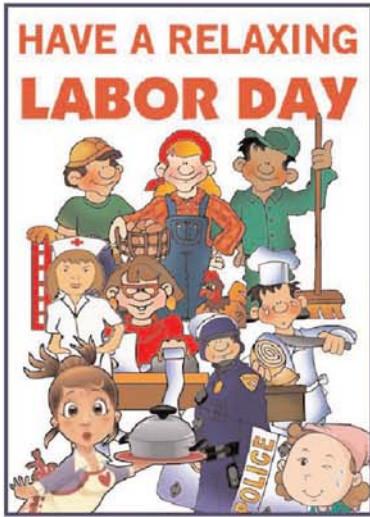

Can you find 5 differences between the two pictures?

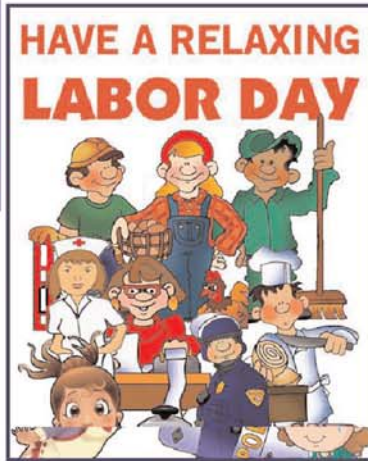

It's the end of the week, can you help these workers get through the maze so they can get paid?



Start

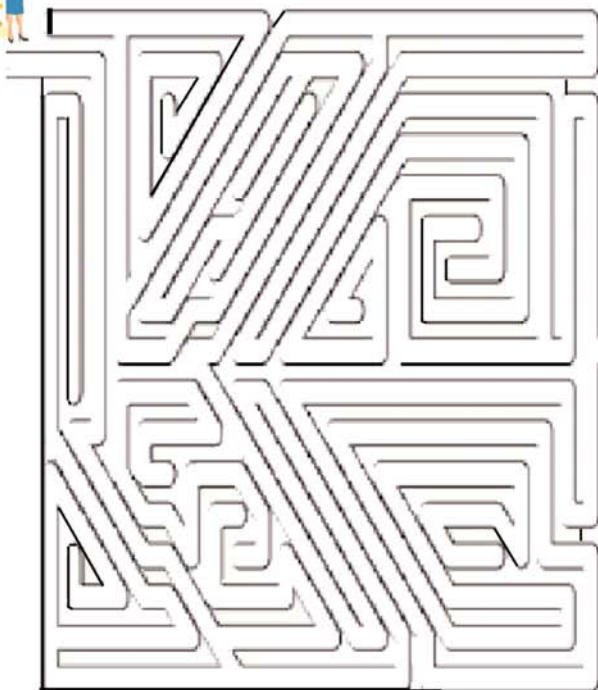

Finish



Labor Day Word Search

Y L C P Y C L E R K
 L B A O F K W K R V
 I R R L N F A Z P K
 B T P I U A I D L C
 R E E C R R T O U A
 A A N E S M R C M S
 R C T T E E E T B H
 I H E Y R S O E I
 A E R J X R S R R E
 N R F I R E M E N R

- CARPENTER
- CASHIER
- NURSE
- FARMER
- WAITRESS
- FIREMEN
- PLUMBER
- TEACHER
- DOCTOR
- CLERK
- LIBRARIAN
- POLICE

Follow the dots to see something a laborer drives.

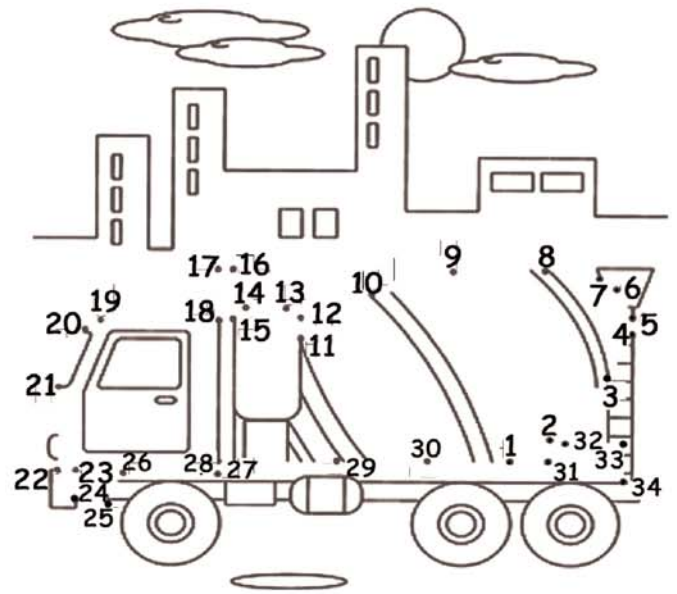

Cryptogram Key

24	4	14	26	11	8	5	15	19	13	7	3	20	25	9	17	23	10	22	6	12	2	21	18	1	16
A	B	C	D	E	F	G	H	I	J	K	L	M	N	O	P	Q	R	S	T	U	V	W	X	Y	Z

LEGALS/PUBLIC NOTICES

TOWN OF NEVERSINK EMPLOYMENT OPPORTUNITY BOOKKEEPER TO SUPERVISOR/PAYROLL/BUDGET OFFICER

The Town of Neversink is accepting applications for Bookkeeper to Supervisor/Payroll/Budget Officer. This a full-time position with benefits included. Salary is 55K to 65K depending on experience.

The Duties of the Bookkeeper involves working in a variety of functional areas in a municipality, including budget, accounting, auditing, and payroll functions. The incumbent will work closely with various departments and will make recommendations on the various aspects of budget and office administration. The work is under general supervision of the Town Supervisor, with considerable leeway for carrying out job responsibilities within established policies and procedures. Typical work activities will include maintaining Town Books per Double-Entry Accounting, preparing financial statements, keep ledger and journal accounts, trial balances, and reviews bank statements. Prepares monthly projection of cash needed and cash available for investments. Maintains written agreements with banks and ensure pledge of securities are maintained. Use of computer applications such as Word, Excel, Outlook, and Town Finance Program.

The duties of Payroll involve processing bi-weekly payrolls and maintain employee payroll files to ensure all necessary forms are authorized and current. Reviews payroll quarterly and annual reports, Federal and State Reports, W-2 for all employees and 1099s.

The duties of Budget Officer involve working with the municipality for the administration of the Town Budget conferring with departmental officials and employees to assist in the preparation of their budget. Prepares tentative, preliminary, and adopted Budget.

Both the Bookkeeper and Budget Officer require attending Public Hearings and Board meeting as needed.

Resume and a Letter of interest are to be received by September 6, 2024. Please either mail to: Chris Mathews, Supervisor, Town of Neversink, PO Box 307, Grahamsville, NY 12740 or email to supervisor@townofneversink.org or hand deliver to the Town Hall, 273 Main St., Grahamsville, NY 12740.

Please address any questions to Supervisor Mathews at 845-985-2262 X301.

8/22; 8/29

District Opening
Tri-Valley Central School

School Aide
(Elementary & Secondary Schools)

Please forward resumes & Tri-Valley's application
(located at www.trivalleycsd.org) by Aug 30th
To: tri-valley_recruitment@scbooces.org
Attn: School Aide Search EOE

8/8; 8/15; 8/22; 8/29

LEGAL NOTICE PUBLIC MEETING

PLEASE TAKE NOTICE that the Board of Fire Commissioners of the Neversink Fire District in the Town of Neversink, County of Sullivan, State of New York, will hold a Budget Workshop Meeting on Monday, September 9th, 2024 at 6:00 PM at the Neversink Fire District's Building located at 7486 State Route 55, Neversink, New York. All meetings of the Board of Fire Commissioners are open to the public.

This notice is being publicized and posted in accordance with the provisions of Section 104 of the Public Officers Law of the State of New York by order of the Board of Fire Commissioners of the Neversink Fire District.

Dated: August 22nd, 2024
Dana M. Vogler Secretary
Neversink Fire District
8/29; 9/5

PLEASE TAKE NOTICE:

The Town of Denning will hold a Public Hearing for Proposed Local Law No. 1 of 2024, Titled: Tax Levy Limit Override on Tuesday, September 10th, 2024 at the Denning Town Hall, 1567 Denning Road, Claryville, NY 12725 set to begin at 6 pm prior to the start of the regularly scheduled Town Board meeting.

At SAID meeting any and all interested person(s) will be heard either for or against.

A copy of the proposed law is available in the Town Clerks Office during normal business hours.

BY THE ORDER OF THE DENNING TOWN BOARD
Nancy Parrow
Town Clerk
August 19th, 2024

8/29; 9/5

**Tri-Valley CSD
Board Meeting**

**Thursday,
August 29, 2024
Special Meeting**

Regular Meetings will be on
Tri-Valley's YouTube LIVE Channel:
<https://www.youtube.com/channel/UCkI224vKQ8nAWWhR6NVao24w/live>

LEGALS/PUBLIC NOTICES

SC ROAD CLOSURE

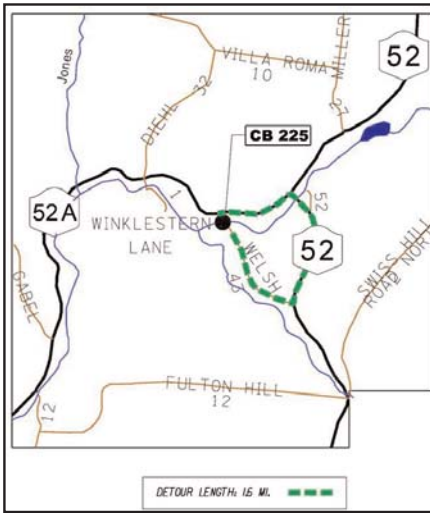

Kenoza Lake, NY - The Sullivan County Division of Public Works will close a portion of Welsh Road in the Town of Delaware to repair County-maintained Bridge 225. The section of road will be closed to traffic starting 7 a.m. on Wednesday, August 14 and will remain closed for approximately five (5) weeks.

The Sullivan County Division of Public Works will post signage for a detour using State Route 52A and State Route 52.

SC ROAD CLOSURE

Lake Huntington, NY - The Sullivan County Division of Public Works is closing a portion of County Road 115 (Odell Road) in the Town of Cocheton to replace County Bridge 472, located immediately west of the intersection of Fred White Rd. with CR 115.

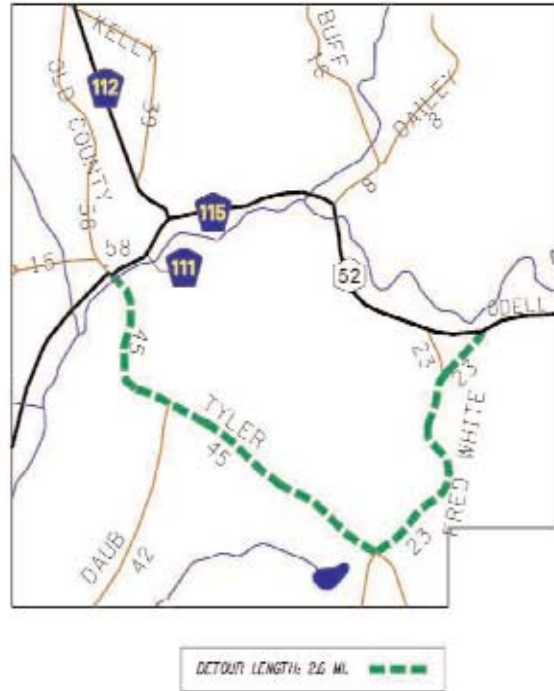

This section of County Road 115 is scheduled to be closed to all traffic starting 8 a.m. August 14, 2024, and will remain closed for approximately three (3) weeks. Travelers will be directed on a detour route using Fred White Rd. and Tyler Rd.

DISTRICT FISH STOCKING PROGRAM

The Sullivan County Soil & Water Conservation District is having our Fall Fish Stocking Program. If you are interested in stocking your pond with crappie, catfish, bass, minnows, sunfish, trout or grass carp, call us at (845) 292-6552 and request an order form to be mailed to you or go to our website at sullivan-swcd.org. The District will be accepting orders until Friday, September 20th 2024.

- All pet owners must clean up after their pets.
- All pets must be at least 3 months old.
- All pets must be in a carrier or on a leash.
- Aggressive dogs should be muzzled to prevent any biting incidents.
- Bring proof of prior rabies vaccination to receive a 3-year vaccination.
- If you do not have proof of prior rabies vaccination, your pet will receive a 1-year vaccination.

BEEHIVE, THE 60s MUSICAL at SHADOWLAND STAGES

<https://www.youtube.com/watch?v=quno69JZeQ0>



Prepare to be swept off your feet by the music that defined a generation! Told from the perspective of six young women coming of age during the enigmatic 1960s, BEEHIVE is a dynamic musical revue that brings the era to life through its unforgettable hits. Get ready to dance in the aisles as you groove to classics like "Proud Mary," "Me and Bobby McGee," "A Natural Woman," "To Sir With Love," "Son of a Preacher Man," and many more!

This family-friendly rock-and-roll revue features a powerhouse cast, including Brandi Knox, Liz Neitge, Jasmine Crosson, Amy Knips, Lizzy Cenicola, and Jasmine Lawrence. Under the direction of our Managing Director Brittany Proia, with choreography by Andrew Geller Karl and music direction by Noel Carey, BEEHIVE is a must-see event that promises to be an unforgettable experience!

Tickets are selling fast-don't miss your chance to join us for this rock n' roll celebration! Secure your seats today and relive the songs that thrilled us, challenged us, and changed the way we see the world.

We can't wait to see you there!

The production will run Thursdays through Saturdays at 8 PM and Sundays at 2 PM until September 8th. Due to the popularity of the production, additional 2 PM matinees have been added on August 24th, August 31st, and September 7th.

Tickets for BEEHIVE, THE 60s MUSICAL at SHADOWLAND STAGES can be purchased online at <http://shadowlandstages.org> or by calling the box office at (845) 647-5511. Tickets are \$46 for evening shows. Tickets for matinee performances are \$43. SHADOWLAND STAGES' MainStage Theatre is located at 157 Canal Street in Ellenville, NY.

Don't miss your chance to experience extraordinary music LIVE on stage!

**GET YOUR TICKETS NOW
UP NEXT**

**The Garbulogists
GET YOUR TICKETS NOW
BUY TICKETS ONLINE AT
SHADOWLANDSTAGES.ORG**

**PHONE OR VISIT THE BOX OFFICE:
845.647.5511**

**NOON - 5PM and BEGINNING TWO
HOURS PRIOR TO CURTAIN
AT THE VENUE WHERE THE SHOW IS
PLAYING**

157 Canal Street, Ellenville, NY 12428

"A SMASHINGLY GOOD TIME"
- SULLIVAN COUNTY DEMOCRAT

Beehive
THE 60s MUSICAL

NOW - SEPT 8 SHADOWLAND STAGES

Time and the Valleys Museum Shop



- stocks over 100 book titles for children and adults
- promotes local artists and craftspeople
- sells unique gifts, souvenirs and toys
- supports the Museum



Shop books online at:
timeandthevalleymuseum.org

332 Main Street (St. Rt. 55) Grahamsville
Open Saturday and Sunday
noon to 4 p.m. through end of September
and by appointment 845 985-7700

Need a last minute gift? Stop By!
Free Admission Anytime!



Time and the Valleys Museum



Connecting Water, People & the Catskills

- Augmented Reality Exhibit:
Bittersweet Memories: Lost Towns of the Catskill Watersheds
- Interactive Exhibits
Tunnels, Toil and Trouble: NYC's Quest for Water and & Water and the Valleys
- 1930s Catskill Family Farm
- New expanded shop



NEW!
Town of Neversink
and Denning Residents FREE
1st Saturday of the month!



Adults: \$5, Children: \$2
Members: FREE

Open Weekends - 12 to 4 - Through September
332 Main Street (St. Rt. 55) Grahamsville
845 985-7700 timeandthevalleymuseum.org

ST. MARK'S UMC
68 Clinton St
Napanoch NY

INDOOR YARD and CLOTHING SALE

Will be opened every Friday from 10 - 3

Something for Everyone!



COLONIAL FAMILY of FUNERAL HOMES

**PRE-PLANNING, FUNERAL & CREMATION SERVICES
VETERAN'S CARE, MONUMENTS & ENGRAVING**

LOCATIONS IN WOODBOURNE, LIBERTY,
MONTICELLO, LIVINGSTON MANOR & KAUNEONGA LAKE

434-7363 292-7160 794-2700 583-5445 439-4333
<http://www.colonialfamilyfuneralhomes.com>

MONUMENTS INSTALLED IN ALL CEMETERIES
CREMATION MEMORIALS & BENCHES, MONUMENT LETTERING & CLEANING

**Sundown United Methodist Church
Covered Dish Supper
5:30 pm
Sept 7, 2024**

Many items from the Indoor Yard Sale will be available for sale at the Supper. Come check them out.

Sundown United Methodist Church Hall

St. Mary's and St. Andrews Church
139 S Main Street • Ellenville, NY 12740

Mass Times
SUNDAY EUCHARIST
5:00 PM Saturday Evening
7:30 AM Sunday Morning
10:00 AM Sunday Morning
(Latin) 11:30 AM Sunday Morning*
(Spanish) 1:00 PM Sunday Afternoon
*Sung Mass 2nd and 4th Sundays

WEEKDAY EUCHARIST
8:00 AM Monday through Friday
9:00 AM Saturday

HOLY DAY EUCHARIST
Schedule will be listed in the bulletin
<https://smsaparish.org/bulletins>

CATHOLIC PARISH OF THE IMMACULATE CONCEPTION
(Embraces Fallsburg, Neversink, Sundown and Ulster Heights)
6317 Rte. 42, Woodbourne, NY

Weekend Mass schedule:
Saturday afternoon: 4:30 pm
Sunday morning: 9:00 am and 11:30 am

Daily Mass Schedule: Monday, Tuesday, Friday, and Saturday
Mass at 8:30AM.
Thursday, 3 pm Divine Mercy Chaplete followed by Mass

Saturday afternoon confessions: 3:45 to 4:15 pm
Rev. Ignas Dhas MMI, Administrator
(845) 434-7643

Grahamsville United Methodist Church

**Thrift Sale
Sept 7th
9 am to 12 noon**

**Grahamsville & Sundown United Methodist Churches
House Worship Plan
Worship Service & Tuesday Evening Bible Study Zoom Link**

Join Zoom Meeting - Worship Service & Tuesday Evening Bible Study Zoom Link
<https://us02web.zoom.us/j/2029912673?pwd=R2lJYUhyTVdsQWdMUXZvTEtCeGdLZz09>
Meeting ID: 202 991 2673 Passcode: 012740
Dial by your location
+1 646 558 8656 US (New York)
+1 312 626 6799 US (Chicago)

The Bible Study continues every Tuesday at 7 pm.
If you are interested in joining the Bible Study, please feel free to contact the
Pastor Harriet Wilkin 845-985-2283

Grahamsville Reformed Church

The Church with a friendly welcome
Pastor Kenneth Ronk
Sunday School 9:30 am
Worship Service 9:30 am
P O Box 238 - Route 55
Grahamsville, NY 12740
845-985-7480

Claryville Reformed Church

Claryville Road
Claryville, NY 12725
845-985-2041



Worship Services @ 10:15 am
Rev. Ken Tenckinck, Pastor
Church Hall available for rent
Call - 845-985-2041 for information

Loucks Funeral Home
Geoff and Heather Hazzard
"Celebrating Life, One Family at a Time"

79 North Main Street
Ellenville, New York
(845) 647-4343

St. Augustine's Chapel
Watson Hollow Rd. • West Shokan, NY

Sunday Mass - 9:30 am
Holy Days 5:30 pm
Penance 9:00 am, 2nd Sunday of the month
Rev. Thomas P. Kiely, Pastor

Ans to last week's Crossword

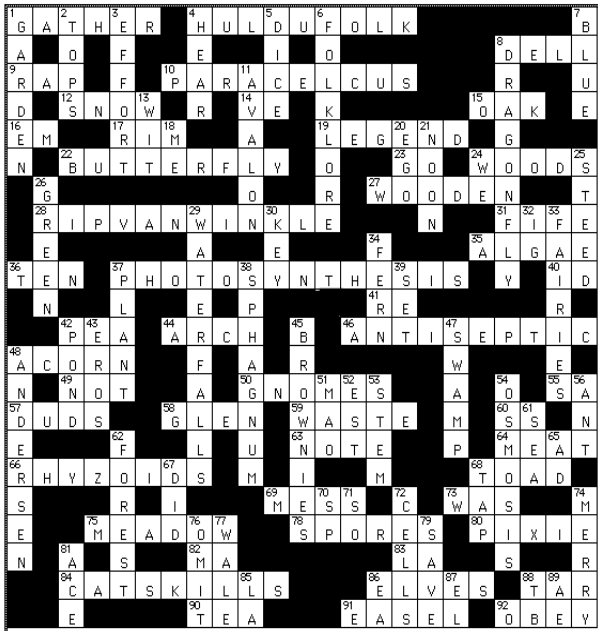

Clip & Save



Grahamsville United Methodist Church

356 Main St. P.O. Box 86
Grahamsville, NY 12740

Thrift Sale Schedule 2024

Sept - 7th and 21st

Oct - 12th and 28th

Nov - 2nd and 18th

Dec 7th - **Holiday Craft Sale**

All sales are from 9:00 a.m. to 12:00 noon
Donations accepted in the thrift building on Tuesdays,
starting March 14, 2024, from 9:30 to 11:30 or by
appointment. Call Ruth at 845-985-7222.
grahamsvilleumc.org - grahamsvilleumc@gmail.com



**Sundown
United Methodist Church
Covered Dish Supper**

Saturday,

Sept 7, 2024 5:30 pm
at the Church Hall

**Check out the tables with Yard Sale items
available for sale**

*(Covered Dish Suppers are held the
First Saturday of each month at 5:30 pm
at the Church Hall)*

All Aboard!
Join the Fun!
Play Mexican Train
FREE FUN
every FRIDAY 1- 4 pm
in the upstairs meeting room
at the Neversink Town Hall

Also
WANTED
People to
play cards

SUUJI WA TANSU NI KAGIRU
answer

8	4	9	2	5	6	1	3	7
7	2	3	8	4	1	6	5	9
1	5	6	3	9	7	2	8	4
3	7	4	5	6	2	8	9	1
5	9	8	7	1	3	4	2	6
2	6	1	4	8	9	3	7	5
6	1	5	9	2	8	7	4	3
9	8	7	1	3	4	5	6	2
4	3	2	6	7	5	9	1	8

\$17.5 BILLION in Lost Money

Every day New York State returns \$1.5 million to those who file claims here. Is any yours? To find out, go to:

<https://osc.state.ny.us/ouf> or <https://ouf.osc.state.ny.us/ouf>

Many have checked, and sure enough after following the directions and filing a claim, have received a check from the NYS Comptroller's Office. It only takes a few minutes to find

SCDW Upcoming Events

Thursday, August 29, 2024 - SCDW auditions for Haunted Theatre Tours - 6:30 - 9:00 PM Rivoli Theatre, So. Fallsburg. Nyx6117@yahoo.com.

Friday, August 30, 2024 - SCDW auditions for Haunted Theatre Tours - 6:30 - 9:00 PM Rivoli Theatre, So. Fallsburg. Nyx6117@yahoo.com.

Check the air quality where you are at:

<https://www.airnow.gov/>

VETERANS always **Free** search of the Archives for family or history of Sullivan County
at the **Sullivan County Museum**, 265 Main St., Hurleyville, NY.
For information call 845-434-8044.

ARTISTS • CRAFTERS
Need a place to show and sell your crafts?
Call us at 845-985-0501
email: tvtownsmen@yahoo.com
or visit our Virtual Mail
<http://gnomehomeinc.com>

9/4/24	Town of Neversink Planning Board Meeting
9/7/24	Grahamsville UMC Thrift Sale 9 am - 12 noon
9/10/24	Denning Town Board & Business Meeting 6:00 pm Denning Town Hall
9/11/24	Town of Neversink Board Meeting 7:00 pm
9/7/24	Sundown UMC Covered Dish Supper 5:30 Church Hall
9/17/24	Claryville Fire District Monthly Meeting 6:30 pm
9/19/24	Neversink Fire District Commissioner Meeting 7:00pm
9/19/24	Denning Town Planning Board Meeting 6:00 pm Denning Town Hall
9/21/24	NRAMA 24th Annual Tractor Show & Community Yard Sale -Grahamsville Fairgrounds 10am-6pm

Save the Date!

Saturday, Sept 21 • 10 am - 6 pm **NRAMA 24th Annual Tractor Show & Community Yard Sale**

TOWN OF OLIVE MEETINGS ARE AS FOLLOWS:

Unless otherwise noted, all **Town Board meetings** are held at the Town Meeting Hall, Bostock Road, Shokan at **7:00 pm**. Town Board Meetings are the **second Tuesday of each month** with the **audit/workshop meetings** being held the **Monday preceding the second Tuesday**.

Town of Olive Planning Board meets the **first and third Tuesdays of each month**. Meetings start at 7:30 PM at the Town Hall on Bostock Road, Shokan, NY. You can contact the Town Building & Zoning Department to confirm a meeting date if you would like to attend at 657-2015. If there is nothing on their agenda, they will cancel meetings.

Town of Denning - <http://www.denning.us>
Town of Neversink - <https://townofneversink.org>

**Ulster County Legislature
Weekly Calendar Update
for the Week Of**

August 26 - 30, 2024

Monday, August 26

o 5:30 PM - Recycling Oversight Committee, in the KL Binder Library, 6th Floor, County Office Building, Kingston & Via Teleconference by Dialing (845) 340-7589, Bridge #123666

o CANCELLED: Climate Smart Committee

Tuesday, August 27

o No Meetings

Wednesday, August 28

o 3:00 PM - Electrical Licensing Board, in the Rondout Municipal Center, 1915 Lucas Avenue, Cottekill 12419

Thursday, August 29

o No Meetings

Friday, August 30

o No Meetings



MISU is a 501c3 nonprofit organization

DRUM CIRCLE at MISU

Every 3rd Thursday of the month from 6-7:00 pm

All ages and abilities are welcome!

Drums will be provided, first come first serve. If you have a drum, bring it!

For more information visit our website

40 Market St. Ellenville

www.misucatskills.org

845.377.3727



@Music Institute of Sullivan and Ulster Counties

@misucatskills

The Skin Ripper

A novel

John Dwaine McKenna

From the award-winning pen of John Dwaine McKenna comes a searing new novel five years in the making . . .

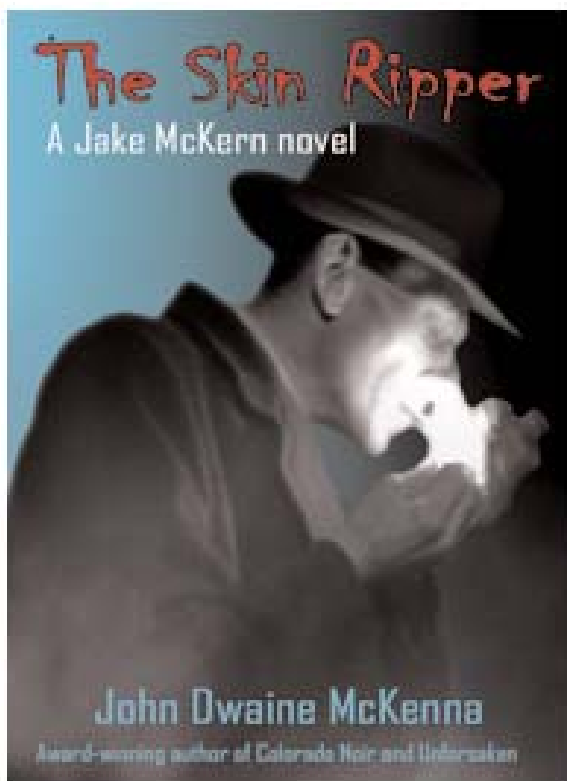

Recently promoted and just out of the hospital after a long recuperation from injuries he received while battling Lee Roy Morgan gang as they were trying to rob Colorado Commercial Bank, Colorado Springs homicide detective Jake McKern is on his first case . . . the double murder of an elderly couple who ran a small grocery on the 'Springs near west side . . . while at the same time, his personal life is crashing down around him.

With the only clue being a handwritten journal in an unknown and indecipherable language, the victims turn out to be Jews who survived Auschwitz and the horrors of the Shoah, the case suddenly takes on an international flavor with world-wide consequences.

The suspense ratchets up with each chapter as the beleaguered detective is drawn ever deeper into a morass of treachery, danger, and personal tragedy. It's Jake's darkest

hour and his greatest adventure to date!

ISBN 978-0-9896763-7-3

325 pages

Price \$19.95

Available Now at:

Neversink General Store

Amazon, Barnes & Noble, Apple
And bookstores everywhere.



COME JOIN US FOR THE
THE NEVERSINK RONDOUT ANTIQUA MACHINERY ASSOCIATION'S
24th ANNUAL TRACTOR SHOW

on

SATURDAY, SEPT. 21 from 10 am - 6 pm (rain date Sept. 22)

at the GRAHAMSVILLE FAIRGROUNDS

COST: \$5 PER CAR

*******IT'S THE YEAR OF THE JOHN DEERE*******

(But all tractor models are welcome!)

Several makes/model tractors & farm equipment w/hit & miss engines, shingle mill, sawmill

A showroom of antique household and farm machinery

Food by our Grahamsville Fire Dept. & Tri-Valley Little League including a Chicken BBQ Dinner

from 4-6 pm (pre-orders available at fd.grahamsville@gmail.com)

Beer Garden w/Bridge & Tunnel brewery & entertainment by **Jon Zanger & DJ Mark Hyser**

Craft, yard sale, sports and machinery equipment vendors

Hayrides, Pedal Tractors, Timmy the Train, Tractor Bingo & more

TRACTOR PARADE @ 1 PM

Trophies awarded for

Best Featured Tractor (John Deere), Best Restored Tractor, Best Original Condition

Tractor, Best Garden Tractor, Best Young Adult (13-21) Tractor,

Furthest Traveled Tractor and to all Tractors from ages 12 and under.

Classic and antique vehicles welcome. Club membership not required.

ALL TRACTORS MUST REGISTER TO PARTICIPATE IN SHOW

Want more info? **Contact: Paul Kelly @ 845-985-0081 or Cher Woehl @ 845-985-2401**

(if no answer leave a message and we'll get back to you as soon as possible)

Check out our NRAMA Facebook Page for additional info on the show and the raffle.



Bittersweet Memories

Lost Towns of the Catskill Watersheds

ARTISTS

LaVerne Black
Kate Hyden

Marcia Fink
Margaret McLaughlin

Caroline Harrow
Valerie Taggart

Ann Higgins
Jennifer Weiss

Maureen Winter

Closing Reception & ART AUCTION!

Sunday, October 6, 2024 2 p.m.

Bids can be placed NOW through October 6th
at Museum, by phone or email.

View paintings at the Museum or on our website! (coming soon)

Time and the Valleys Museum

332 Main Street Grahamsville NY - 845 985-7700 - info@timeandthevalleymuseum.org

Open Weekends through September 30, noon to 4 p.m. and other times by appointment



Who is the Healthiest Fire Department? Naming Sullivan County's Healthiest Fire Department at this Year's Parade

[Liberty, NY] -The Sullivan 180 Healthiest Fire Department Challenge will conclude on September 1; with winners being announced at the 95th Annual Sullivan County Volunteer Fireman's Parade on Saturday, September 7, hosted by Livingston Manor Fire Company. The two departments that earn the most "turtle points" will be eligible for a grant in the amount of \$15,000 and \$10,000, respectively. Additional grants will be awarded based on a tiered system and "Turtle Awards" in the amount of \$500 will be given to departments that excelled in specific health-based activities.

"Each year, nearly one hundred American firefighters die in the line of duty. Among those tragedies, nearly half are potentially avoidable by making lifestyle changes to reduce stress-related illness. Certainly, the fire service in general is well aware of these risks - many have worked for decades to educate firefighters in the benefits of healthy living - and thankfully there has been some success to that end. But the truth is, much more needs to be done, and I can think of no greater initiative to directly combat firefighter health-related death and injury than wellness programs like The Healthiest Fire Department Challenge." - Commissioner, Division of Public Safety, Scott Shulte.

Since January when the challenge kicked off, 19 departments have engaged in activities (challenges) to enhance the physical and mental health of their members. Departments received credit in the form of "turtle points" for each health focused activity they completed. Activities ranged from serving healthier meals during drill and meeting nights; joining as a department family and hiking or walking local trails; attending health related seminars and becoming trained in suicide prevention. There were even water consumption and weight loss challenges, sleep tracking and sugar shakedowns, a way of counting sugar intake and going sugar free.

"Our local volunteer firefighters tirelessly dedicate themselves to protecting our families and community. It's time for us to give back to those who give so much, by supporting their efforts and ensuring they have the resources to stay safe too," said Lindsay Wheat, Outreach Program Manager for Sullivan 180.

The parade steps off at 2:00 p.m. on the corner of Rock Ave and Main Street by the Citgo, ending at the Livingston Manor Firehouse located at 93 Main Street. The award ceremony begins at approximately 5:30 p.m. All are welcome to watch the parade and cheer on the departments.

Sullivan 180 is working to build a healthy community, one degree at a time, through people, places and policy with support from Bold Gold Media Group, Manor Ink, The River Reporter, The Sullivan County Democrat and WJFF Radio Catskill. Learn more at Sullivan180.org or Facebook.com/Sullivan180inc.

Sun Trail Storage

Sun Trail is a local family-owned business
God Bless America
Located on the Corner of Hill Top Rd
and Route 55 Grahamsville, NY





**Hours of
Operation:**
7 AM - 9 PM
Every day
of the week
Call (845) 985-7923
or
(914) 672-3952

Please call for availability first

Help your
local business grow
Advertise locally in
The Townsman!

Classified ads - \$5.00
for the first 20 words/
20 cents each additional word

Display Ads

1" Boxed ad (1"x3")-
\$7.50 per week
Business card ad (2" x 3")
- \$15.00 per week
(3" x 4") - \$30.00 per week
(3" x 6") - \$45.00 per week
1/4 pg (4" x 5") - \$50.00 per week
1/2 pg (4"x8") - \$80.00 per week
Full Page - 8" x 10" - \$100.00 per week
Digital Flyer Insert - 8"x10 - \$100.00/week

Sign up for quarterly billing and get
a 20% discount

.. Full Page Flyer for
Local Municipalities
and Organizations -
one time fee- \$20.00
(once the flyer is inserted
we will publish it each week
through the week of the event)

As in the past, there is no fee for
advertising for our local churches

Low Rates
High Visibility!

Regina Giordano named Fallsburg CSD's Assistant Director of Pupil Personnel Services

FALLSBURG - The Fallsburg Central School District is proud to name Ms. Regina Giordano as their newest Assistant Director of Pupil Personnel Services.

Ms. Giordano previously served as a Special Education teacher at the Fallsburg Junior-Senior High School for fourteen years. In 2023, she enrolled in the district's Grow Our Own administrative internship program, which allows teachers to explore a potential career in an administrative role by working under the guidance of a current administrator.

Ms. Giordano believes that the internship and her experience as an educator has prepared her well for the position. When asked about her goals as the new Assistant Director, she stated that she hopes to gain a better understanding of the programs and mechanisms of Pupil Personnel Services so that the needs of students are adequately met.

"Having fourteen years [of experience] not only as a teacher but as a teacher in this district, I understand the needs of the district and the kids," said Regina. "Having that knowledge will allow for me to be as successful as possible."

The district wishes to congratulate Ms. Giordano on her new role and is excited to see the impact she will make on the district.

Learn how to Operate Tractors with CCE & SG Tractors!

LIBERTY, NY - Tractor Operation is one of the most important aspects of farm operation and ownership. To show resident farmers the basics of tractors and how to run them, Cornell Cooperative Extension Sullivan County's Beginner Farmer Program is working with SG Tractors to host a training on Tractor Operation. This workshop will take place from 9:00 AM to 4:00 PM on Friday, September 13th at Stone Wall Farms in Jeffersonville, NY.

Participants will meet with and learn from SG, workshop educator from SG Tractors. Participants will learn from SG about the 4-stroke engine and how the parts of a tractor function, basic maintenance, safety, manuals, dashboards, symbols, levers, and how to operate a tractor. This will be an interactive workshop, with opportunities for questions throughout the day. This workshop will be held in an outdoor covered space. Participants are asked to dress for the weather and pack a lunch. Restrooms will be available for participants to use.

There is no fee, but pre-registration is required to participate. Participants can register online at sullivancece.org/events. Those with related questions can email Taylor Adam at beginnerfarmer@cornell.edu, or call 845-292-6180 ext. 130.

This program is supported by the USDA National Institute of Food and Agriculture award #2022-06508, through the American Rescue Plan Technical Assistance Investment Program.

Cornell Cooperative Extension Sullivan County provides equal program and employment opportunities. The public can contact the office to request accommodations.

Management & Budget Commissioner Appointed New Budget Director Also Named

Monticello, NY - Sullivan County Manager Joshua Potosek is pleased to announce his appointment of Anna-Marie Novello as the new Commissioner of the Division of Management & Budget, unanimously confirmed by the Legislature this past Thursday.

"Anna has served the residents and taxpayers of Sullivan County for 10 years, steadily adding to her responsibilities and reputation over that decade," Potosek related. "Her eye for detail and her problem-solving capabilities make her perfect for this new role, and she'll work closely with me to prepare budgets and oversee the finances of all of County government."

"I'm grateful the County Manager and the Legislature have placed such trust and confidence in me, and I hope to further that in the years to come, starting with our 2025 Budget development," Novello stated. "I am fortunate to work with a great team all around, and I can promise taxpayers we will handle their monies responsibly and transparently."

In addition, Lucrezia Anderson, former Town of Wallkill Comptroller and Senior Accountant in various Sullivan County government offices, has been named Budget Director, replacing the now-retired Janet Young.

"Lu has been an integral part of our operations for a cumulative 14 years, and I look forward to integrating her common-sense approach into our financial oversight and budget preparations," Potosek remarked.

"Continuing my career in Sullivan County government has been rewarding and fulfilling, and I'm delighted to be part of a group of people dedicated to using public funds wisely and accountably," said Anderson. "I'm thankful to County Treasurer Nancy Buck, with whom I started, and to the County Manager and my coworkers for the opportunity to learn as much as I have."

About Anna-Marie Novello

Novello has spent a significant portion of her career with County government, where she has served as an Account Clerk, Financial/Budget Analyst and, most recently, the Office of Management & Budget's Senior Budget Analyst. In that role, she has overseen the payroll of 1,000 Sullivan County employees, analyzed and forecasted financial trends and concerns, ensured budget compliance, and maintained the timekeeping system. The work has touched on every department and office in the County.

"I love my job - I really do," she affirmed. "I find it challenging and fulfilling to use my skills to improve processes and systems throughout the County."

Novello grew up on Long Island and graduated from William Floyd High School, finding her way to Sullivan County while taking care of a friend's horses.

"I met Heather Brown, long before she became the Planning Commissioner, and she told me County government was a great place to work, so I took the Civil Service test and got the call," she recalled, adding that the two remain friends and plan to enjoy a mutual interest this fall: skydiving. (Contd. Pg. 30)



Management & Budget Commissioner Appointed New Budget Director Also Named

(From Pg. 31) She currently lives in Monticello with her two daughters: Krista, a nursing student, and Hannah, a brand new high school grad. She also shares her home with her cat, Tut, and her rabbit, Whiskers.

Novello holds a Master of Science in Accountancy from the University of Phoenix and is a member of the NYS Government Finance Officers Association. As Sullivan County's Management & Budget Commissioner, she'll be overseeing 19 people - many of whom she's routinely worked with already.

"I love teaching people," she noted, "and I truly do feel part of a team that's making a difference."

About Lucrezia Anderson

Anderson grew up in Newburgh and graduated from Valley Central High School but now lives in Bloomingburg with her husband of 15 years, Peter, and their children: Antonio, 12, and Peter III, 8.

"We wanted to start a family near where I grew up," she acknowledged. "It was important to raise our kids close to family."

Possessing a Master's of Business Administration from the University of South Florida, Anderson first worked as an accountant at a payroll and HR consulting company in St. Petersburg, Florida.

"I was dead-set on not being an accountant - which is what I became!" she explained with a laugh. "I found out I just like numbers."

Anderson joined Sullivan County government in 2010 as a Senior Accountant in the Treasurer's Office, working under then-County Treasurer Ira Cohen and then-Deputy Nancy Buck. After a stint as the Town of Wallkill's chief fiscal officer, she returned to Sullivan County as a Senior Accountant in the Budget Office. She has been crucial in keeping track of the Legislature's Discretionary Grants Program and the various Local Development Corporations, training fiscal staff, analyzing the County's financial policies and processes, and submitting the necessary data to receive Federal and State reimbursements that offset taxpayers' costs.



Eastern Equine Encephalitis Confirmed in Ulster County Virus is Rare and Can Only be Transmitted by Mosquitoes

KINGSTON, NY - On Wednesday, August 21, the New York State Department of Health (NYSDOH) issued an advisory urging New Yorkers to take personal protective measures to avoid mosquito bites, after confirming the presence of Eastern Equine Encephalitis Virus (EEE) in horses in eight New York State counties, including one horse in Ulster County.

There is no risk of infected horses spreading the virus to humans or other horses, as EEE is transmitted from mosquito bites, and there are currently no confirmed human cases in New York State.

The infected horse in Ulster County, which subsequently died, was in Wallkill, and other horses on the owner's property have been vaccinated and boosted to help prevent further spread. The Ulster County Department of Health and the Ulster County Executive's Office are working closely with NYSDOH to monitor this case and any other cases that may appear in Ulster County.

EEE is a rare but extremely serious viral disease spread by infected mosquitoes that can affect people and horses. People of all ages are susceptible to infection, but people over 50 and younger than 15 are at greatest risk. While most people bitten by an infected mosquito will not develop any symptoms, severe cases may begin with the sudden onset of headache, high fever, chills, and vomiting. The illness may then progress to disorientation, seizures, encephalitis, and coma.

While there is no commercially available human vaccine for EEE, the best protection is to prevent mosquito bites by utilizing the following proven precautions:

- When spending time outdoors at dusk or dawn, when mosquitoes are most active, wear long sleeves and tuck pants into socks and shirts into pants.
- Use insect repellents containing DEET, according to direction, and always have adults apply repellents to children.
- Eliminate all standing water in yards and around the home and property where mosquitoes can breed.
- Make sure there are screens in windows and doors of your home. Make sure the screens are free of rips, tears, and holes.
- Additionally, horse owners should consult with their veterinarian and make sure their animals are up to date on vaccinations for EEE, West Nile, and other viruses spread by mosquitoes. Horses cannot spread EEE to humans or other horses, however EEE can cause serious harm and/or death to horses.

Mosquito season in Ulster County and the Hudson Valley generally begins in mid-Spring, and lasts until late Fall; however, climate change has caused average temperatures, and the duration of warm weather, to increase and lengthen.

For more information, visit the New York State Department of Health online at: www.health.ny.gov/diseases/communicable/eastern_equine_encephalitis/ or contact the Ulster County Department of Health at: HealthEd@co.ulster.ny.us.



Last Indoor Yard Sale
for this year!
Items discounted &
Bargains galore!
Fill a Bag for \$5.00 table!



Friday, Aug 30 & Sat, Aug 31 • 9am-1 pm

Saturday - Hot Dogs • Chips • Water
will be available for sale

Sundown United Methodist Church Hall
Intersection of Sundown, Peekamoose & Greenville Roads
Sundown, NY 12740

SLAC Senior Legislative Action Committee of SC Monthly Meeting

10 AM, Friday, August 30, 2024,
in the Legislative Meeting Room, at the Sullivan County
Government Center, Monticello NY

Through the efforts of SLAC members and coordinating with our Assembly woman Aileen Gunther, there will be a town meeting on September 6th at 11:00 AM at the government center in the legislative hearing room. Jerry Dunlavey, who is Chief Executive Officer, Garnet Health Medical Center - Catskills and Vice President of Operations for the system will be present to answer questions from the Senior Legislative Action Committee and the public.

The purpose of the SLAC meeting on the 30th is to:

1. Develop the procedure and ground rules for the town hall meeting.
2. List of questions to be presented to the CEO.
3. Update on the ACC
 - a. Certificate of Need process
 - b. Financial reconciliation reports

UC Executive Jen Metzger Lauds Legislature's Approval of Expanded Eviction Prevention Program

KINGSTON, NY - Ulster County Executive Jen Metzger issued a statement today applauding the Legislature's passage this week of a resolution enabling the County to expand its Eviction Prevention Program and offer additional supports to rent-burdened County residents.

The Ulster County Legislature unanimously passed a series of resolutions in July and August that significantly expands the County's eviction prevention program. The bipartisan initiative extends and expands a contract with Legal Services of the Hudson Valley (LSHV), enabling LSHV to double its efforts in assisting residents facing eviction, including providing additional legal representation and housing counseling and in some cases, funding to assist with arrears.

The urgency of this expansion is underscored by the Ulster County Planning Department's newly-released 2023 Rental Housing Survey Report, which shows that 46% of the County's residents are rent-burdened and 26% are severely rent-burdened.

The resolution for the expanded program was co-sponsored by Majority Leader Abe Uchitelle and Minority Leader Kevin Roberts.

"Addressing the housing crisis is a top priority for my administration and for the County Legislature," said County Executive Metzger. "These more robust eviction defense services will provide a lifeline to residents at risk of losing their homes, and I want to thank Majority Leader Abe Uchitelle and Minority Leader Kevin Roberts for their bipartisan championship of this program."

"The expanded Eviction Prevention Program is a much-needed piece of the housing puzzle alongside our investments

creating new affordable units and improving the quality of existing housing for low-income tenants," said Majority Leader Abe Uchitelle, Chair of the Legislature's Health, Human Services, and Housing Committee. "By keeping residents facing eviction out of taxpayer funded hotels and shelters, we are able to keep more residents in their homes while also helping landlords with tenants in arrears become whole."

"The expansion of this program marks a significant step forward in our commitment to supporting the residents of Ulster County," said Ulster County Legislator and Minority Leader Kevin Roberts. "By expanding the County Eviction Prevention Program, we are doubling down on our efforts to provide critical legal representation and housing counseling to those facing eviction. This expansion, made possible through bipartisan support and the dedication of our Legislature, ensures that we can better address the urgent needs of our rent-burdened community. Together, we are building a more resilient and supportive environment for all our residents."

UC Executive Jen Metzger Recommends Five Housing Projects for Funding through New Housing Action Fund

*\$2 Million Proposed for Affordable,
Emergency Housing*

KINGSTON, NY - Ulster County Executive Jen Metzger has recommended \$2 million in support from the newly-created Ulster County Housing Action Fund for five affordable housing and emergency housing projects in Ulster County.

The Housing Action Fund closed the Year 1 application window on May 10, 2024. In June, the Housing Policy and Oversight Committee (HPOC), the body established to oversee the implementation of the Housing Action Fund, reviewed applications and made recommendations to the County Executive for consideration. Based on the HPOC's review, County Executive Metzger is recommending that the County Legislature release \$2 million from the Housing Action Fund to support five projects, all of which meet the Fund's affordability and sustainability requirements:

- \$300,000 to the Affordable Housing Conservancy for the development of Harmony Hall, a 51 Unit Permanent Senior (62+) Affordable Rental Housing development in the Town of New Paltz.
- \$500,000 to RUPCO for the Quality Inn Conversion Project in the Town of Ulster, an 83 unit permanently affordable and supportive housing development for homeless individuals or families with unmet housing needs.
- \$400,000 to the Affordable Housing Conservancy for eight new affordable manufactured homes at the Gallis Hill Manufactured Home Park in the Town of Hurley.
- \$400,000 to Ulster County Habitat for Humanity for the development of the Jeffrey Court project in the Town of Saugerties, a subdivision with 10 new affordable homes developed for homeownership.
- \$400,000 to the Kingston City Land Bank for the Third Avenue Housing Development in the City of Kingston, an approximately 50 unit new, affordable housing development on a vacant infill site in the city.

The Legislature will take up the County Executive's recommendations at the September 17 legislative session.

"Ensuring that every resident of Ulster County has access to safe, affordable housing is not just a policy goal, but a moral imperative," said County Executive Metzger. (Contd. Pg. 33)

UC Executive Jen Metzger Recommends Five Housing Projects for Funding through New Housing Action Fund

“(From Pg. 32) By investing \$2 million from the Housing Action Fund into these five critical projects, we are taking a significant step toward addressing the urgent housing needs of our community. All of these projects, moreover, meet our strict energy and sustainability requirements, which is good for the environment and good for residents' health and their pocketbooks. I want to thank the members of the Housing Policy and Oversight Committee for their diligence and hard work in reviewing the applications for funding.”

“This investment from the Housing Action Fund underscores our dedication to tackling the housing crisis head-on,” said Peter Criswell, Chair of the Ulster County Legislature. “The proposed projects will have a lasting impact, providing much-needed affordable housing options and fostering a sense of security and dignity for our residents. The Ulster County Legislature remains committed to continuing this critical work to ensure housing for all.”

“I am incredibly excited to see the projects recommended by the Housing Action Fund oversight committee come before the legislature,” said Majority Leader Abe Uchitelle, Chair of the Legislature's Health, Human Services, and Housing Committee. “This marks a significant step toward a sustainable housing investment that is transparent, begins with an open application process, and is led by experts in tackling the housing crisis. I thank County Executive Metzger for stewarding this process, and I look forward to working with my colleagues in the legislature to move these forward.”

“I fully support Executive Metzger's recommended allocation of \$2 million from the Ulster County Housing Action Fund. This allocation will support the creation of over 200 permanently affordable and emergency housing units in our county,” said Jeff Collins, Ulster County Legislator and Chair of the Housing Subcommittee. “This is an important step in helping to address our county's housing needs, and it will result in a significant reduction in the number of our unhoused residents. We all know that resolving our housing crises will take time, energy, commitment, and money. We also know that we need housing solutions throughout the county. These five recommendations will create housing in New Paltz, the Town of Ulster, Hurley, Saugerties, and Kingston. This proposal starts the process of bringing housing to the people of Ulster County.”

“On behalf of the Housing Policy and Oversight Committee, I want to thank the County Planning Department Staff for their insights and efforts as we evaluated these critical projects,” said Fawn Tantillo, Chair of the Housing Policy and Oversight Committee. “We are not just building homes, we are building a stronger, more inclusive community. The Housing Action Fund is a testament to Ulster County's commitment to ensuring that every resident has access to safe, affordable housing.”

In August 2023, the Ulster County Legislature approved a resolution spearheaded by County Executive Metzger to create a \$15 million Housing Action Fund to support the creation of healthy, energy-efficient, and climate-responsible housing units that serve households making up to 80% of Ulster County Area Median Income, with an emphasis on housing that serves the county's most vulnerable populations. All projects funded by the HAF must be highly energy efficient and all-electric, consistent with the County's climate and energy goals. The positive response and success of Round 1 of the Housing Action Fund demonstrates the effectiveness of the fund as a tool for building housing that is both affordable and sustainable.

For more information on the Ulster County Housing Action Fund, visit the Participate Ulster website here:
<https://participate.ulstercountyny.gov/housing-action-fund>.

Governor Hochul Directs College Campuses to Prepare for Fall Semester, Develop Emergency Safety Plans

- **On a Call With Leaders From More Than 200 New York Colleges and Universities, Governor Emphasizes Safety Expectations and Highlights Resources Available for Campus Leaders**
- **State Officials Will Review Campus' Emergency Plans To Ensure All Students Are Able To Attend Classes Safely**
- **Builds on Governor's Actions To Keep Campuses Free From Violence, Hate and Harassment**

Governor Kathy Hochul today met with leaders from over 200 college and university campuses in New York State as well as public safety experts to reinforce the importance of emergency plans ahead of students returning to campus for the fall semester. With increased need to monitor and respond to campus protests and potential threats to student safety, Governor Hochul, State Police and the Division of Homeland Security and Emergency Services met to reinforce expectations and connect campus leaders with necessary resources.

“Public safety is my top priority, and as classes resume, it is essential that all students feel safe and are free from harm,” Governor Hochul said. “Last spring, I directed college campuses to review and update their emergency response plans, and as tensions may be high as we start the academic year, I will continue to ensure all campus leaders and public safety officials have the resources they need to keep students safe.”

In the Spring of 2024, the Division of Homeland Security and Emergency Services (DHSES) conducted reviews of campus emergency response plans and conducted multiple training sessions with higher education institutions across New York State. Throughout the summer, the New York State Police worked closely with campuses to enhance emergency planning, and remains committed to working with college campuses to ensure comprehensive measures are in place to protect the school communities.

These training sessions were consistent with and informed by the recently released Campus Planning Toolkit from the U.S. Department of Education. This toolkit provides law enforcement, university administrators and campus leaders with a methodology to maintain both student safety and civil liberties on campus, centered on building resilient campuses, planning for crisis response, maintaining engagement through a crisis and individual and community recovery.

Today's call is Governor Hochul's latest action to address hate, bias and antisemitism on campus. Last year, she wrote a letter to all colleges and universities in New York, reiterating their obligation under New York State's human rights law and Title VI of the federal Civil Rights Act to provide an educational setting free of harassment and discrimination. The letter was sent following a Congressional Hearing on Antisemitism where several university presidents failed to denounce antisemitism and calls for genocide on college campuses clearly and unequivocally.



The Neversink Association, Inc.

To conserve the flora and fauna of the Neversink River

Like us on Facebook!

*If you would like to receive information from us,
email us at neversinkassociation@gmail.com.*

ANNUAL BYO PICNIC & MEETING

Sunday, September 1, 2024 NOON

Location: Harlow "Junction Pool"

73 Tannery Way, Claryville, NY

Rain Location: Claryville Reformed Church Hall

DUES REMINDER

\$20/household, \$10/individual. Mail to:

Neversink Association

PO Box 134

Claryville, NY 12725

MEETING AGENDA

1. Riel Peerbooms talk - Frost Valley YMCA
2. Board members talk about Fishing the Neversink
3. Fly Fishing Demonstration for adults and kids in the Neversink River

Neversink Association T-shirts

Photo: Laura Brock

Live Music
at the
Russian Mule Brewery
August Line-Up
Saturday's 5-8pm

8/3 - Andrew Mercer
8/10 - Albi Beluli
8/17 - Andre Turan
8/24 - BJ Hendrickson
8/31 - Jon Zanger

www.russianmulebrewery.com
1465 Denning Road, Claryville, NY

OPEN

BUSINESS HOURS

THURSDAY	3 PM	TO	8 PM
FRIDAY	3 PM	TO	9 PM
SATURDAY	12 PM	TO	9 PM
SUNDAY	12 PM	TO	6 PM

MORE INFORMATION
(845) 985-0247
www.russianmulebrewery.com

kitchen closes 1 hour prior to closing



LIVE CHARITY AUCTION SEPTEMBER 21

***PRESENTED BY THE
ELLENVILLE REGIONAL
HOSPITAL AUXILIARY***

All funds raised will be dedicated to acquiring equipment to enhance the experience and care of patients at Ellenville Regional Hospital

CONTACT INFORMATION:

HAZE GAL
CALL/TEXT: 516-356-7687
EMAIL: HGALI2420@GMAIL.COM

LOCATION:

HUNT MEMORIAL BUILDING,
LIBERTY SQUARE ELLENVILLE NY
ON-LINE AND IN PERSON BIDDING

PREVIEW DATE:

FRIDAY, SEPTEMBER 20, 12-3 PM

**AUCTION DATE - IN PERSON &
ONLINE:**

SATURDAY, SEPTEMBER 21
BIDDING STARTS AT 12:30 PM

FREE ENTRY

Governor Hochul Announces Additional 2024 Free Fishing Day to Help New Yorker's 'Get Offline, Get Outside'

*Freshwater Fishing License Requirement Waived on August 31
New Yorkers Encouraged To Explore Outstanding and Affordable Fishing Opportunities*

Governor Kathy Hochul today announced that Labor Day weekend will kick off with the addition of a new Free Fishing Day in New York State for the 2024 season. The addition of the Saturday, August 31 Free Fishing Day, for a total of seven Free Fishing Days in 2024 in New York State, complements the Governor's "Get Offline, Get Outside" initiative launched this summer to promote physical and mental health by encouraging kids and families to put down their phones and computers, take a break from social media and enjoy recreation and the outdoors.

"There is no better way to send off summer than adding fishing to your Labor Day weekend plans," Governor Hochul said. "Reel in the beauty of New York's extraordinary natural waterbodies and take advantage of this affordable opportunity to enjoy the holiday weekend with family and friends."

During free fishing days, the fishing license requirement is waived for freshwater fishing on New York's waters. The Free Fishing Days program began in 1991 to give people who might not fish a chance to try the rewarding sport of freshwater fishing at no cost, introduce people to a new hobby and encourage people to support conservation by purchasing a New York State fishing license.

New York State Department of Environmental Conservation Interim Commissioner Sean Mahar said, "As summer winds down, it's the perfect time to get outside, enjoy nature, and fish with family and friends. Fishing can be enjoyed by anyone, regardless of age or ability, and I encourage both new and practiced anglers to use this bonus free fishing day to throw out a line and experience New York's world-class fisheries."

To help make fishing even more affordable, DEC has partnered with libraries across the state to provide a free fishing rod lending program. In addition to borrowing a book, library patrons can sign out a fishing rod. This program offers an opportunity for people to try fishing before purchasing their own gear. For more information and a list of participating libraries visit DEC's website. <https://dec.ny.gov/things-to-do/freshwater-fishing/learn-to-fish/i-fish-ny-programs#loaner>

DEC also offers a host of resources for those interested in getting started in fishing. The I FISH NY Beginners' Guide to Freshwater Fishing provides information on everything from rigging up a fishing rod to identifying catch and understanding fishing regulations. There's also a video series on DEC's YouTube channel that complements the Beginners' Guide.

DEC's Places to Fish webpages are a reliable source of information when planning a fishing trip. DEC's official app, HuntFishNY, features "The Tackle Box." Fishing regulations, boating access, and stocking information are all available

ROURKELAW.COM

845.292.2000



ROURKE LAW

*Your Trusted
Counsel in the
Catskills*



25 Darbee Lane, Liberty



**REAL ESTATE • CIVIL • FAMILY • DWI
ESTATES & TRUSTS • INJURY & MORE**

within a map-based interface from the convenience of a smartphone. Anglers can also access their sporting license information. For those looking to fish the Great Lakes, DEC recently highlighted the Outstanding Great Lakes Fishing Opportunities.

During designated free fishing days, New York residents and non-residents are permitted to fish for free without a fishing license. Free fishing day participants are reminded that although the requirement for a fishing license is waived during free fishing days, all other fishing regulations remain in effect. In addition to Free Fishing Days, there are also "learn to fish" opportunities available through DEC-approved free fishing clinics. An event is being held today at the Great New York State Fair. For a list of scheduled events, visit DEC's website.

DEC recently revamped its Angler Achievement Awards Program, which recognizes anglers that catch notable-size fish, including state records. The new and improved program broadens the list of eligible fish species an angler can enter for an award and now features a "Youth Angler" category and an online entry form where qualifying catches can be submitted from the convenience of a smartphone. All anglers who submit a qualifying catch will receive a species-specific sticker to proudly display on their tackle box, vehicle, etc. For official program rules, eligible species and associated minimum qualifying lengths, visit the Angler Achievement Awards webpage on DEC's website.

Anglers are reminded that the New York State Department of Health (DOH) provides advice about what fish are safe to eat and how often. Visit DOH's website to search by waterbody location.

International Overdose Awareness Day Vigil

*Time to remember.
Time to Act.*

Monticello, NY] The Fourth annual International Overdose Awareness Day Vigil will be held on August 29th at 6 pm on the lawn of the Sullivan County Courthouse, 414 Broadway, Monticello.

International Overdose Awareness Day is the world's largest annual campaign to end overdose remember without stigma those who have died from overdose; and acknowledge the grief of the family and friends left behind.

According to the New York State Department of Health, Sullivan County holds the highest rate of overdose per capita in New York State. Last year the county was federally designated as a High Intensity Drug Trafficking Area (HIDTA). Being classified as a HIDTA means that Sullivan County is recognized as a critical area for intervention and support, necessitating a coordinated response from local, state, and federal agencies to combat drug trafficking and its associated consequences.

“International Overdose Awareness Day both commemorates those who have been lost to the disease of addiction and serves to inspire those who are still struggling to seek recovery. In its 4th year, this has become an annual event where our community gathers as a united front to let people know that we are all in this together and there is hope,” said Camille O'Brien, Coordinator of the Sullivan County Drug Task Force.

Open your hearts as families share their stories of loved ones who lost their battle with substance use. Remember those who have passed and celebrate those in recovery. Meet organizations and learn about resources created to face this crisis head-on. Participate in a candlelight vigil as the sun sets. Hear from state and local leaders who will share efforts to battle the opioid crisis in Sullivan County.

Nesin Cultural Arts, and bagpipers will perform



**BECOME
SOMEONE'S
Angel**

Donate a little of your time and have a direct impact on someone's path to recovery!

HOPE
not HANDCUFFS
www.hopenothandcuffshv.com

against the backdrop of the Sullivan County Courthouse, lit purple to symbolize overdose awareness.

“This evening serves as a platform for so many things. Each loss to overdose was someone's someone; a brother, a child, a parent, or a best friend,” said Lindsay Wheat, Outreach Program Manager for Sullivan 180. “We always knew this was an important evening, but each year, we realize how necessary it is. The only way to end this is to do it together.”

International Overdose Awareness Day Vigil is presented by a community of organizations working together to end the opioid epidemic in Sullivan County.

Sullivan 180 is working to build a healthy community, one degree at a time, through people, places and policy with support from Bold Gold Media Group, The River Reporter, The Sullivan County Democrat, Manor Ink and WJFF Radio Catskill. Learn more at Sullivan180.org.

Find Your Adventure - Catskills Fire Tower Challenge, Love Our New York Lands Stewardship Days, Fishing Access, and More!

The lazy, hazy days of summer are upon us and it's a great time to complete the 2024 Catskills Fire Tower Challenge before the kids head back to school! All you need to do are visit the fire towers at: Overlook Mountain; Hunter Mountain; Red Hill; Balsam Lake Mountain; Tremper Mountain; and Upper Esopus Fire Tower (located at the Catskills Visitor Center!)

Take some fun photos, download and complete the Challenge Log (PDF) and email it to CatskillsChallenge@dec.ny.gov along with your favorite photo(s). The Challenge Log can also be submitted by mail to New York State of Environmental Conservation, Outdoor Recreation, 625 Broadway, Albany, NY 12233-1020, or you can also complete the log at SurveyMonkey. The towers must have been visited between January 1, 2024 and December 31, 2024, and entries must be postmarked by January 6, 2025. The first 1000 finishers will receive a one-year subscription to the DEC's Conservationist magazine, and all finishers receive a commemorative 2024 Fire Tower Challenge Patch and an entry into the grand prize drawing. Participants who have completed the challenge more than once will receive an additional commemorative Catskills Fire Tower Challenge prize.

Don't forget to check the weather conditions before you head out. The Catskills Visitor Center also posts weekly trail updates for the Catskills, as well as other great events happening in the Catskills. And as always, make sure to Love Our New York Lands, Hike Smart, and Leave No Trace™.

Love Our New York Lands Stewardship Day Event Registration Is Open!

Volunteer registration is now open for Adirondack and Catskill Park Day on Saturday, September 7, and Fish and Wildlife Day on Saturday, September 28! Show your appreciation for New York's diverse and beautiful public lands by participating in one of these stewardship opportunities.

Adirondack and Catskill Park Day highlights New York's unique Forest Preserve lands by offering service projects throughout the Adirondack and Catskill Parks. Help with a campground cleanup after a busy summer season or participate in a trail maintenance project to support sustainable outdoor recreation.

Fish and Wildlife Day offers stewardship projects and educational workshops that focus on wildlife and conservation. Help remove invasive species to foster healthy wildlife habitat, build a birdhouse that will benefit native species, or participate in a birding walk or fishing clinic to learn about the importance of wildlife conservation.

Gather your friends and family and join your community in helping to preserve and protect New York lands! Volunteer today by visiting the Parks & Trails New York website.

Adirondack and Catskill Park Day and Fish and Wildlife Day are part of the Love Our New York Lands Stewardship Days Campaign, an effort created in partnership with Parks & Trails New York, the Canal Corporation, New York State Parks, and DEC.

Check out our other stewardship opportunities! <https://dec.ny.gov/get-involved/living-green/protect-fish-wildlife-open-space/stewardship>

The 2024 Love Our New York Lands Photo Contest launched earlier this summer with monthly themes that will run through mid-October.

For August, the theme is "Accessible Recreation," and photographers are asked to highlight participants of all ages and

JIM YORK
163 Krumville Road, CR2A
Olive Bridge, N.Y. 12461

State and Federally Licensed
(845) 657-6330 (Ph.)
(845) 657-7031 (Fax)
Email: jyork@hvc.rr.com

JIM'S GUNSMITHING, INC.

www.Jimsgunsmithing.com

CUSTOM STOCK, METAL WORK, BLUEING,
GENERAL REPAIRS, SIGHTWORK, ETC.
BUY - SELL - TRADE - TRANSFERS

Start at Route 28 and Reservoir Rd in Shokan 1.7 Miles
 ← Turn LEFT onto Monument Road
 Continue onto NY-28A West 1.8 Miles
 ← Turn LEFT onto NY-213 1.1 Miles
 → Turn RIGHT onto Krumville Road/CR-2A 0.8 Miles
 Gun Shop on LEFT

Start at Route 209 and 213 in Stone Ridge
 -Going Towards Olivebridge 7.5 Miles
 ← Turn LEFT onto The Krumville Road/CR-2A 0.8 Miles
 Gun Shop on LEFT

Bingo at the Monticello Elks Lodge

Every Tuesday at 7 PM

46 North Street in Monticello

For information contact Past Exalted Ruler **Ronni Scannell** at (845) 701-0695

abilities camping, picnicking, fishing, boating, hiking, nature viewing, and more in the great outdoors. Submissions for the Accessible Recreation theme will be accepted until August 31, 2024, and three winning pictures will be chosen to feature creative shots of the public enjoying activities at accessible recreation sites across New York State.

The winning images from the photo contest will be featured in statewide digital and print campaigns to increase awareness of important principles and guidelines that encourage safe, accessible, respectful, and sustainable use of the public lands that we all share.

Fishing Access Has Expanded!

Fishing access has expanded in Delaware County! The new Cadosia Fishing Access Site in the town of Hancock has been completed, a project further supporting the state's "Get Offline, Get Outside" initiative, launched earlier this summer to encourage New Yorkers to take a break from phones and computers and enjoy outdoor recreation. The Cadosia site is also just one of the many boat launch sites found across the state. Check out the Places to Fish page on the DEC website to find a fishing access site near you, as well as free digital I FISH NY Guides to Fishing in your region. New to fishing and want some guidance? Find a FREE Learn to Fish clinic coming up near you!



Tri-Valley Reunion – Classes pf 1964, 1965 and 1966

*Come join us as we gather together to celebrate
58, 59 and 60 years of memories
from Tri-Valley School!*

Dates: Monday, September 23 – Wednesday, Sept 25, 2024

Lodging: A block of rooms has been reserved for Tri-Valley reunion participants at the Resorts World Catskills a./k/a Monticello Casino

• 833-586-9358; Booking Code 2411

There are other hotels/accommodations in the area if you choose

Events:

Monday, September 23, 2024

- 3:00 Check-in and/or join us at the Main Lobby of the Casino
- The reunion will begin at Resort's World Casino with a **Meet and Greet** in the Alder Annex. There will be No-Host Mexican fare and bar options available.

Tuesday, September 24, 2024

- 12 Noon - **Tour of Grahamsville's "Time and the Valleys" Museum and the Daniel Pierce Library** (\$5.00 Museum donation)
- 4:00 **Guided Tour of Tri-Valley Central School - "A Trip Down Memory Lane"**
- 5:30 Join your classmates at the Grahamsville Fair Grounds for **Brisket and Rotisserie Chicken Dinner** catered by the Neversink General Store. Dinner cost will be covered by each guest, the amount to be determined by September 10th as the final count is made.

Wednesday, September 25, 2024

- 11:00 Meet at the **Museum at Bethel Woods** for a tour and light brunch at 12:30 - courtesy of Sandra Bertholf Gerry. Farewells will follow:

The classes of 1964, 1965 and 1966 are happy to extend this invitation to the siblings of our classmates.

*** Please RSVP on or before September 6, 2024.**

* In your RSVP, please indicate the names and number of attendees as well as the events you will be attending so that we can pass on that information to the venues.

* Additionally, if you would like, please feel free to include a message to your classmates via email or U.S. mail to Peggy LaPolt Mumford, 35 Cranes Lane, Brewster, MA 02831

Contacts: Peggy La Polt Mumford
(508) 241-0301
mum022542@aol.com

Eric Bernstein
(815) 531-2705
ebernte@me.com



**SUNDOWN
UNITED METHODIST
CHURCH
ANNUAL CHICKEN BBQ**

Saturday, September 14, 2024 ~ 4 -7 PM



FOR TICKETS CALL
KEN TER BUSH 845-693-1034
OR
JOHN BARNUM 845-985-7065





At 8:00 am this past Saturday, the Claryville Firehouse looked like an empty hall. By 9:00 am the tables began to transform into a colorful display of crafts. By 10:00 am the doors opened to the public who got to see and shop for the most amazing crafts. There was crocheted and knitted items; quilted items; handcrafted jewelry; crystals and gemstones; homemade jams, jellies and honey; natural 'handmade in the Catskills' skin care, fragrances and more; handcrafted items for Halloween and even Christmas...and more! It was a fun day for all. If you missed this year's be sure to mark the calendar for next year and spend some time at the 2025 Claryville Vol. Fire Dept Annual Craft Sale!



Time and the Valleys Museum Shop



- stocks over 100 book titles for children and adults
- promotes local artists and craftspeople
- sells unique gifts, souvenirs and toys
- supports the Museum



Shop books online at:
timeandthevalleymuseum.org

332 Main Street (St. Rt. 55) Grahamsville
Open Saturday and Sunday
noon to 4 p.m. through end of September
and by appointment 845 985-7700

Need a last minute gift? Stop By!
Free Admission Anytime!





Sundown
United
Methodist
Church



Sept. 7th, 2024
5:30 pm

Bring a covered dish to share
Enjoy good food and fellowship

and don't forget to check out the tables
filled with a variety of collectibles,
household items and more
that will be available for sale

Sundown United Methodist Church Hall

(Intersection of Sundown Rd., Peekamoose Rd. & Greenville Rd., Sundown, NY 12740)

Got History?

Get Museum Membership & FREE Admission to over 30 Museums for only \$25 a year!

- ◆ Free admission to all in-person and virtual programs
- ◆ Free admission to the Museum and Catskill Farm
- ◆ Invitations to exhibit openings and special events
- ◆ *Around the Reservoirs* Newsletter
- ◆ Monthly historical and informative emails
- ◆ 10% discount in the Museum Shop
- ◆ FREE admission to over 30 other museums in New York State



Join NOW and get a free art catalogue!

Join at the \$100 (Patron) level for FREE admission to thousands of museums all across North America!

Time and the Valleys Museum, P.O. Box 254, Grahamsville, New York 12740
 845 985-7700 or join online: www.timeandthevalleymuseum.org

- Individual \$25
- Double \$40
- Family \$50
- Patron \$100
- Patron Silver \$200
- Patron Gold \$500

Name: _____

Address: _____

City: _____ State & Zip: _____

Phone: _____ e-mail: _____

Thank you for supporting local history and the Museum

Time and the Valleys Museum

P.O. Box 254, 332 Main Street, Grahamsville NY 12740



WE WANT YOU!

Do you have crafts you want to sell?

Do you have outdoor and sportsman equipment you want to sell?

Do you have gently used items you want to sell?

Do you have antique household and small farm equipment you want to display?

Do you have tractors or antique vehicles you want to show off!

Are you 13-21 years old with a special tractor? We have a trophy category just for you!

And for those of you 12 and under with your very own tractor, we have trophies for you!

If you answered YES to any of the questions then **WE WANT YOU!**

Come join us at the **24th ANNUAL NRAMA ANTIQUE TRACTOR SHOW**

On **September 21st** (raindate Sept. 22nd)

At the **Grahamsville Fairgrounds** (Grahamsville NY)

From **10-6**

Be part of a fun day filled with tractors, farm machinery displays and demonstrations:
live entertainment; craft, sports & yard sale vendors;

beer garden with Bridge & Tunnel local brewery; and lots of food including the Grahamsville Fire Dept. famous chicken BBQ (from 4-6).

For more info on the **tractors and antique vehicles** contact Paul Kelly @ 845-985-0081

***For more information on **how to become a vendor** or if you have any **antique household & small farm equipment you want to display** contact Cher Woehl @ 845-985-2401 OR at cherwoehl@gmail.com ***
(LEAVE A MESSAGE IF NO ANSWER)

Check out our NRAMA Facebook page for more details on the show and info on how to get your raffle tickets (for some incredible gift card prizes!)

MONTIGRAM President's Corner

Lori Orestano-James



We are so lucky to have Leo Katyes as our District 7210 Governor. Both he and District Governor Nominee Carrie Hernandez visited our club for our Board Meeting and Regular Meeting. They shared their vision and long term goals with us. In addition, they reminded us that our club moves forward by working together and seeking out broader membership and programming. Leo also reminded us to read the District Newsletter that comes out weekly for

a lot of information of happenings around District 7210. Everyone at the meeting felt this was a great meeting to learn about our role in the District and how the District serves our membership. All agreed that Leo, Beau (DG Elect), and Carrie are "User Friendly," and are excited for the year ahead.

Also, we would like to thank Luis and his amazing crew at El Sombrero for a terrific meal and use of the dining room for our meeting while Albella was closed for renovations. We are lucky to have such wonderful community minded restaurant establishments in our community.

As a reminder, there will be a Monticello Youth Services



Committee Meeting before our Meeting on Tuesday, August 27 at 5:30 back at Albella Restaurant. Please see the story below from Chair Cris Spinner.

Thanks to all who joined in the fun of Humpback Friday. Our next Humpback Friday will be on Friday, September 16, 2024 at 5pm - 7pm. Location to be announced. Please Save the

Date on your calendar.

Our Speaker this coming week is Julian Dawson, Executive Director for United Way. We do a lot with United Way and hearing from Julian will prove to be a good update on the great work of United Way in our community.

Our next big event around the corner is our Annual Scholarship Golf Outing to be held on September 14, 2024 at Tarre Brae Golf Course. Please reach out to Chair Bob Ernst and Randy Katz for more information. We are seeking Raffle Baskets, Foursomes, Sponsors, and Day of Event Volunteers. Please help us to secure the funds for our Scholarship Foundation and find your way to assist for this event.

Our Motto: Service Above Self - How have you meet that goal lately?

Dates to Remember can be found below.

Agenda for August 12, 2024

1. Meeting Called to Order - President Lori Orestano-James
2. Pledge Of Allegiance - Vice President Cris Spinner
3. Introduction of Guests of Members - Full Membership
4. Guest Speaker - Julian Dawson, Executive Director, SC United Way
5. Committee Reports:
 - Joint Club Blood Drive (Lori James)
 - Monster Run (Check Presentation - Brad Rutledge, Brad Matican)
 - Scholarship Golf Outing - Bob Ernst & Randy Katz 9/14/24
 - FBG at Forestburgh - 9/21/24 Brad Rutledge
 - Alzheimer's Walk at Bethel Woods 9/28/24 at 10am Barbara Carr
 - Community Unity - Lori Orestano-James 10/5/24
 - Rotary Radio - Rick Stein
6. Regional Updates/District Updates
7. Old Business
8. New Business
9. Happy Dollars
10. 50/50 Raffle
11. Adjourn

Link for Zoom Meeting Sign-on:

<https://us02web.zoom.us/j/88506100931?pwd=MUNmWnhZanR6M21CSy9McjNQSTBudz09>

Some upcoming important dates to mark on your calendar:

Annual Scholarship Golf Outing - September 14, 2024
Far Beyond Gone - Forestburgh Playhouse Tavern - September 21, 2024

Alzheimer's Walk - September 28, 2024 10am - Bethel Woods

Lastly, our meetings are hybrid. We would love to see you at our meetings either in-person or and/or Zoom. For those of you who attend regularly, we thank you for your commitment.

With Rotary Pride,

Lori Orestano-James

President Monticello Rotary 2024-2025

Monti Rotary Donates Computer to Food Pantry

Food Pantry Volunteers look on as Rotary Club of Monticello, NY President Lori Orestano-James (Lori James) presented a computer to Rev. Meg Stapleton-Smith of the St. John's Episcopal Church, Monticello, NY for the Food Pantry Volunteer's use of inventory and record keeping to keep the program running smoothly. Special thanks to Monticello Rotarian and Past President Dr. Jeff Weinstein who donated the computer on behalf of Monticello Rotary.

Stories

Monti Rotary Donates Computer to Food Pantry

Food Pantry Volunteers look on as Rotary Club of Monticello, NY President Lori Orestano-James (Lori James) presented a computer to Rev. Meg Stapleton-Smith of the St. John's Episcopal Church, Monticello, NY for the Food Pantry Volunteer's use of inventory and record keeping to keep the program running smoothly. Special thanks to Monticello Rotarian and Past President Dr. Jeff Weinstein who donated the computer on behalf of Monticello Rotary.

(Contd. Pg. 47)

MONTIGRAM President's Corner

(From Pg. 46) **Monti Rotary Donates Computer to Food Pantry**

"We know there is significant need in our community in the area of food insecurity and we are proud of the partnership we are developing with this Food Pantry to assist," said Weinstein.

"Monticello Rotary continues its commitment to helping feed those in our community through this project as well as our upcoming Annual Thanksgiving Food Drive on Saturday, November 23, 2024 from 9am - 1pm. We will have pre-drop off site locations this year as well and will update locations closer to the event," said Orestano-James.

Welcome Merri White



We are so happy our Rotary club is growing with new members! We'll be spotlighting new members in our stories! Introducing Merri White. She writes..

Hi this is Merri White born and grew up in Ellenville New York.

I'm a retired Registered Nurse. I have one son Justin who I am proud of. I live in Neversink. I am a Senior Companion Caregiver and if anyone needs help you can call on me! I have a loving heart and I'm proud to be a Rotarian!

Welcome Merri! We are happy to have you!



Inspiring Our Youth

One of the committees Cris Spinner is overseeing this year is the YOUTH SERVICES committee. Interact, RYLA, and Youth Exchange all fall under this umbrella. And Cris (we) need YOU! This Tuesday August 27th we will have our first Youth Services meeting at 5:30pm at Albella Restaurant. Please consider joining one of these subset committees and help inspire our young adults to Service Above Self by being a part of Rotary! Cris is looking forward to a robust group to share and create new ideas to benefit our youth. See you Tuesday!

Monticello Rotary Membership Committee Update

The Membership Committee met Tuesday 8/13 prior to our full meeting.

The Committee discussed developing a more robust new membership orientation program. It would include expectations of members regarding financial and personal involvement. A great new idea was brought to the table potentially having new members be assigned a "Rotary Buddy" that would be a go to for them for all things Rotary. This "buddy" would help a new member acclimate and make the most of their membership. The committee members felt we could all do a better job of telling our story and "why we Rotary". To that end, they discussed creating a handheld postcard that has information on our club and what we do. In addition a QR code could be placed on the back that would lead to a website with the same information and a way to sign up or become involved! Lastly a discussion for having a booth next year at the Bagel Festival to promote Rotary and try to gain interest and new members!

Bravo Membership Committee! We are off to a great start!

Read more...

School Days - A Way To Help

At our last meeting Brad Rutledge told of a School Supply Givaway that Lyndie Kirk, his associate and account manager at

Keats Insurance Agency, and her husband are organizing.

The supplies are for any child in need in our area regardless of school attended. The drive will be hosted at 45 North Main Street in Liberty NY on 08/31/24 at 1pm until supplies last.

Donations can be made at The Rec Center, at the above location or Cashapp : \$LadyK9923.

Thanks in advance to all who feel so inclined to help!! I have attached the picture of the event flyer for the School Supply

Giveaway Event!

In addition, Brad Matican shared another way to assist.

Here is a school supply fundraiser going on right here in Monticello! The Black Library's school supply fundraiser is going on between now and the 30th of August! The giveaway for these supplies will be happening on the 31st. All supplies collected will be given to Monticello students of all ages who are in need. Let's support the efforts of our community members who are doing good things in our neighborhoods!

LETTERS TO THE EDITOR/READERS:

Democracies Threatened By Autocracies

Alan W. Dowd in The American Legion Magazine of July 2024 comprehensively describes the plight of world democracies countering the expansionism and exploitation of one-man rule autocracies. I paraphrase him at times. In essence he says the free world needs "an alliance of democracies" against the autocracies of Russia, China, North Korea, Iran, Cuba and Venezuela.

Deterring the autocracies requires the free world to increase defense spending and collaborating in mutual programs designed to enhance the capabilities of democracies to counter the provocations of the autocracies. NATO countries in Europe are now increasing their defense spending to counter Russian expansionism. Far East countries are aligning and spending more money on armaments to confront China and North Korea. Some Middle East countries are working closely with the United States to combat Iranian aggression.

The United States, as the world bastion of democracy, has to ramp up the availability of armaments, including state of the art offensive weapons and defensive weapons like drones, hypersonic missiles and other advanced missile systems. Maybe we should look at developing drone aircraft carriers. This necessitates increasing military spending from 3% of GDP to 5% or 6%.

Donald Moskowitz

Londonderry NH

Dear Townsman Readers:

Mountainkeeper is dedicated to safeguarding the Catskill Park and Forest Preserves, a crown jewel of our region and one of the largest, most ecologically diverse natural areas in the East. Our Catskill Park Trail Stewards program, in partnership with the Catskill Center and supported by New York State, helps protect this treasure by guiding visitors to recreate responsibly.

https://www.catskillmountainkeeper.org/r?u=g6PFEtM3LZZHRSTdsZSkqNPJt4FH_IpuXyY9fJFhJKfUOWzMdd98OrYA9ebkWpQnuYBdQt-Cq--P1EhmcVRUQ&e=bcff9b4954e87a9937341abb8272169c&utm_source=catskillmountainkeeper&utm_medium=email&utm_campaign=8_17_24_newsletter&n=2

Between May and July, our stewards welcomed 4,352 visitors, 214 dogs, and even 1 cat at key sites like Big Pond, Alder Lake, the Beaverkill Covered Bridge, Peekamoose Blue Hole Lower Field Campground and the Neversink Fishing Access Point.

We'll continue tabling through Indigenous People's Day in October and are gearing up for Adirondack and Catskill Park Day on September 7, with a Big Pond Clean Up & Walk from 10:30-12:30. The event is free, and we hope you'll register to join us!

With thanks,

Ramsay Adams, Executive Director



ACTION TOWARD INDEPENDENCE ANNUAL BACKPACK PROGRAM 2024

***PROOF OF ELIGIBILITY REQUIRED
SUPPLIES ARE LIMITED**

***To assist Sullivan County students
K-12, who have an IEP, 504 or are
enrolled with OPWDD.**

 **AUGUST 19 - 30TH**
At 10 AM - 4 PM

 **ACTION TOWARD INDEPENDENCE**
309 East Broadway
Monticello, NY 12701



**FOR MORE INFORMATION AND
TO REGISTER**

 **845-794-4228**

 **www.atitoday.org**



ACTION TOWARD INDEPENDENCE
PROGRAMA ANUAL DE MOCHILAS 2024
 *SE REQUIERE COMPROBANTE DE ELEGIBILIDAD
 LOS SUMINISTROS SON LIMITADOS

*Para ayudar a los estudiantes del condado de Sullivan desde jardín de infantes hasta el grado 12, que tienen un IEP, 504 o están inscritos en OPWDD.

 **AUGUST 19 - 30TH**
 At 10 AM - 4 PM

 **ACTION TOWARD INDEPENDENCE**
 309 East Broadway
 Monticello, NY 12701



PARA MÁS INFORMACIÓN Y PARA REGISTRARSE

 **845-794-4228**

 **www.atitoday.org**

SAVE A LIFE! DONATE! SHARE OUR STORY!



NICK NEEDS KIDNEY -TYPE O (IN SOME CASES TYPE A BLOOD COULD WORK)

Chronic Kidney Disease (CKD) progresses in stages and, if untreated, can lead to complete loss of kidney function. At CKD stage 5, when both kidneys fail completely, the only options for survival are dialysis or a kidney transplant. Nick is at stage 5.

If interested in donating please contact Westchester Medical Center and speak with a Living Donor Coordinator at 914.493.1990

More about our warrior Nick....

Nick was diagnosed with Tuberous Sclerosis Complex (TSC) at birth. TSC is a neurological disorder that produces seizures, tumors, and lesions that effect the organs of the body and can cause Autism. Nick has been battling with seizures his whole life from infantile spasms to adult grand-mal seizures. May 2019 we heard the worst news that Nick's function was under 10% on both kidneys. Since then Nick has had multiple surgeries so he could get the proper dialysis preformed. Nick goes in center for 4 hours 3 times a week. Not what the sweetest, kindest, 31 year old should be going through.

Nick has such a big heart and is loved by so many in our community. We all want Nick to have the best quality of life and going through dialysis does not provide that quality. We hope and pray a kidney comes to us and that Nick will be able to live a happy and healthy life doing what he loves and that is to bicycle all throughout our town making people smile. Nick is a big part of the community, he takes pride with his volunteer work with the EMS and is the Honorary member of the Monticello Fire Department.

Lets all band together for Nick and help him find a kidney so he can live life to the fullest!

*For any other questions
845.798.2077 nickneedsokidney@gmail.com*

 Follow Nick
[@nickneedsokidney](https://www.facebook.com/nickneedsokidney)



Catskill Veterinary Services, P.C.

"Life Saving to Life Changing"

Happy LABOR DAY

URGENT CARE HOURS WITH CONTINUED HOSPITAL MONITORING AT OUR ROCK HILL LOCATION



Hours
 Friday 8/30 8:30 AM - 9:00 PM
 Saturday 8/31 8:30 AM - 6:00 PM
 Sunday 9/1 9:00 AM - 4:00 PM
 Monday 9/2 9:00 AM - 9:00 PM

Visit www.catskillvetservices.com
 More info 845-796-5919

Location
 230 ROCK HILL DR
 ROCK HILL, NY 12775



HPAC Latin CULTURE FEST

SEPT. 14TH
 12PM-4PM

CALL FOR TRADITIONAL LATIN PERFORMERS!

WE'RE ON THE LOOKOUT FOR VIBRANT TALENT TO SHOWCASE THE RICH CULTURAL HERITAGE OF LATIN AMERICA AT OUR UPCOMING EVENT!

WE'RE SEEKING:

DANCE PERFORMERS: SALSA, BACHATA, MERENGE, CUMBIA, BOLERO, & MORE!
 MUSICIANS: MARIACHI BANDS, SALSA BANDS, FLAMENCO GUITARISTS, ANDAN, FUSIONISTS, & OTHER TRADITIONAL STYLES
 OTHER TRADITIONAL ENTERTAINERS: STORYTELLERS, POETS, & ANY UNIQUE CULTURAL ACTS.

For more information
 Email Maria Hernandez at Maria@hpacny.org
 or call 845-985-4722

HPACNY.ORG
 219 MAIN STREET, HURLEYVILLE



Register Today!

Monticello Rotary Foundation Scholarship Golf Outing

Saturday, September 14, 2024

Tarry Brae Golf Course
 South Fallsburg, NY

Rotary 

seventh annual summer group show
 juried by Melinda Stickney-Gibson

July 20 – September 7, 2024
 Opening: Saturday, July 20, 3 – 5 pm

Robin Adler, Naomi Altarenski, Harriet Forman Barrett, Samantha Brinkley,
 Julia Carmolli, Heather Caulfield, Linda Champankur, Maggie Dawiczak,
 Carol Davis, Das Likin, Lina Linton, Donnie Borodillo, Claudia German,
 Patricia Grigolo, Martina Hill, Usueara Hints-Strauss, Danielle Holke,
 Stephen Horowitz, Sue Horowitz, Tom Phillip, Gary Laszlo, Nabil Kozmole,

MONOCHROMATIC

Carole Kunstadt, Anne Leibr, Sheryl Levine, Madreen Luban-Bremer,
 Helene Manzer, Kate Masters, Ann Morris, Raymond Neutron, Jacqueline Ostar,
 Susan Phillips, Tracy Phillips, Lesley A. Popen, Lileen Power, Joe Weilly,
 Deborah Duggan, John S. Thiner, shee in the catskills, Roberta Siskler,
 Michelle Sidrane, Jan Sosnowitz, Tisa Stanger, Daniela Valer, Claudia Waruch

OLIVE FREE LIBRARY
 4033 Route 78A, West Shokan, NY
 olivefree.org / 845.857.2402

Partly sponsored by
 BRAD ALPHE

VENDOR SPACES
 STILL AVAILABLE FOR
 Hosted by the Kiwanis of Woodridge, New York Foundation, Inc.

**4th Annual
 FALLSBURG FALL FESTIVAL**
 Saturday, Sept. 21, 2024,
 10 A.M. - 4 P.M.
 Green Avenue, Woodridge, NY

VENDORS  FOOD

Hula Hoop Contest

GAMES RAFFLES

Children's Scavenger Hunt,
 Crafts, Rides, and More

LIVE ENTERTAINMENT
 For more information
 or to request a vendor form, please contact
dsenn10151@aol.com



ANY MAKE ANY MODEL CAR CLUB

BOX 25

CLARYVILLE, NEW YORK 12725

PHONE 845-985-2943 or 845-985 7162

EMAIL bungst01@gmail.com GLENN

EMAIL tmatthewsm88@gmail.com TOM

2024 SHOW DATES

SATURDAY 9/21/24 OUTPOST BBQ SHOW

ANY MAKE ANY MODEL CAR CLUB SHOW, 6611 ROUTE 209 KERHONKSON, NY 12446

SHOW TIME 10:00 AM UNTIL 5:00 PM JUDGING 1:00 PM TROPHIES GIVEN OUT 4:00 PM
 PRICE PER VEHICLE \$15.00 TROPHIES WILL BE: TOP 25; KIDS CHOICE; JUST BECAUSE;
 CLUB PICK; OUTPOST BBQ CHOICE AND BEST OF SHOW.

THE THIRD ANNUAL VET FEST 2024

PRESENTED BY

28
SEPT
2024

TIME:
1100-1600



GRAHAMSVILLE FAIRGROUNDS
GRAHAMSVILLE, NY

A DAY OF VETERAN LIFE ENRICHMENT WITH
HOBBY & OCCUPATIONAL INFO & DEMOS,
VENDORS, MUSIC, FOOD, & FUN

MUSIC BY
VETERAN GREEN BERET DEREK STONER
ALONG WITH JESSE NOREN & ALBI BELULI

VETERANS, THEIR FAMILIES, AND MEMBERS OF
OUR COMMUNITY WELCOME!

WOODWORKING
STEEL FORGING
ANIMAL THERAPY
WRITING

HORSESHOE TOURNAMENT
GUIDED HUNTS

LURE MAKING
ARCHERY
AXE THROWING
FLY TYING

Homeschooling Group

4th Tuesday of each month

1:00 – 3:00 p.m.

at the Daniel Pierce Library

We invite all homeschooling families to join a self-guided group that meets monthly at the Daniel Pierce Library.

Together this group will share lessons, network, set up future field trips, have various guest speakers and programs.

You can also... borrow books, check out DVD's, access the internet, research online databases and utilize library space! (If you have a RCLS library card).

Please join in, the possibilities are endless!

**Text or call Dana
for more information:
845 707 – 2489**

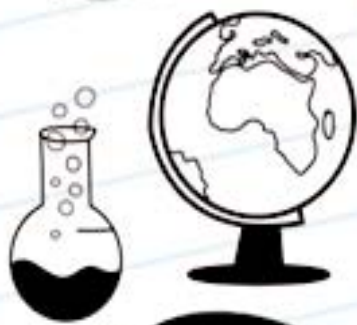

**Beginning
September
24th**





Community Art Series Exhibit

The Library has begun hosting art exhibits in the Robert D. Norris Community Room featuring a rotation of talented local artists.

This month's exhibit...

"Symphony in Color"

by Adrienne Walker



"In the Garden"

The Opening Reception will be held

Saturday, August 10th,

1:00pm – 3:00pm

Please join us as we welcome Adrienne and her beautiful artwork.

Refreshments will be provided.

Exhibit Viewing from

Saturday, August 10th – Friday,

August 30th

For viewing availability, please call the front desk before planning your visit.

Adrienne Walker has been passionate about art her entire life. A native New Yorker, she now resides in Boynton Beach, FL, and Smallwood, NY. Her work has been exhibited in many shows and galleries in New York, Florida and South Carolina.

Using oils, watercolor and acrylics, she creates worlds in many dimensions. Her work is created with passion from within, allowing her brushstrokes to invite the viewer into her art. She loves the challenge of trying something new and creating different emotions in her work.



Monticello-Ethelbert B. Crawford Public Library
479 Broadway Monticello, New York 12701-1300 (845)794-4880
<https://ebcpl.org>





Nothing is better than peak summer in the Hudson Valley, and we took full advantage this last week! From introducing my new housing agenda to tackle the housing crisis in the Hudson Valley to unveiling my legislation to protect Social Security and partnering with local law enforcement to keep our families safe, here's a look at all I've been up to:

LOWERING THE COST OF HOUSING

We have a housing affordability crisis in the Hudson Valley and we need all-hands-on-deck to lower housing costs. That's why I'm introducing a bold agenda to attack every angle of the housing emergency, with solutions focused on the specific problems facing the Hudson Valley.

We need to lower mortgage rates, crack down on the Wall Street firms jacking up housing costs, and cut through red tape to let our towns and cities build in a way that makes sense for them. Read more about my plan here.

No family should have to pick between putting food on the table and having a roof over their heads - I'll keep fighting every day to bring housing costs down.

INTRODUCING THE PROTECTING SOCIAL SECURITY ACT

As the far-right continues to push for cuts to Social Security, I introduced my Protecting Social Security Act to send a message once and for all to our seniors:

There will be no cuts, your benefits are protected, and they should be easily accessible.

With the economic pressure we're all feeling right now, the last thing anyone should be worried about is feeling secure in their retirement.

Social Security represents a sacred promise made by our country to our seniors - you worked your whole lives for these benefits, and in return, we have your back. I've got your back, and I won't rest until Social Security is protected for good.

WORKING WITH LOCAL LAW ENFORCEMENT TO KEEP OUR FAMILIES SAFE

Supporting law enforcement and first responders shouldn't be partisan - it's about delivering for the men and women who put their lives on the line every day to keep us safe.

That's why I'm fighting for over \$2.3 million in federal funding for the Dutchess County Sheriff's Office and Dutchess County Government.

For months, I've worked with Sheriff Imperati, County Executive Serino, and District Attorney Parisi on applications for federal funding for the Real Time Crime Intelligence Center and a new two-way public safety radio system. The projects will be absolute game-changers for Dutchess County first responders. Read more about the projects here .

Together, we're going to cut down on crime, shrink response times, and continue to make Dutchess County a safer community for everyone. Watch here!

BRINGING ONE-ON-ONE ASSISTANCE WITH SOCIAL SECURITY AND MEDICARE DIRECTLY TO YOU

I'm fighting to strengthen Social Security and Medicare and make them more accessible for every Hudson Valley senior.

That's why I launched the C.A.R.E.S. Van Social Security and Medicare tour to bring direct assistance from my team of case-workers, the Social Security Administration, the Medicare, and dozens of community partners to seniors right in their own community.

Last week, we kicked off the tour at the Esopus Community Center and I'm excited to announce that the event postponed from August 9th has been rescheduled for Wednesday, August 28, from 11AM to 2PM at the Newburgh Armory.

Hope you'll join one of the events!

Last Wednesday also marked 89 years since the Social Security Act was signed into law by NY-18's very own President Franklin Roosevelt.

Every day, I'm fighting to protect Social Security for the over 150,000 NY-18 seniors, disabled workers, widows, and children who rely on the vital program.

If you need assistance accessing Social Security, but can't attend one of the C.A.R.E.S. Van Social Security and Medicare tour events - my team is always here to help! Please reach out to us at (845) 443-2930 or here on my website.

DEMANDING AN INVESTIGATION INTO PRICE GOUGING BY WALL STREET PRIVATE EQUITY FIRMS

Wall Street speculators are buying up houses and jacking up prices on hard-working families across the Hudson Valley. It's textbook price gouging and they must be held accountable.

That's why I'm demanding the Federal Trade Commission investigate private equity firms for price gouging.

What do you expect to happen when working people are going head to head with multi-billion dollar monopolies?

The private equity firms rake in record-breaking profits, and everyone else is left holding the bag. It's time to level the playing field. Read more here .

BRINGING MY OFFICE TO YOU

Everyone deserves the assistance they need right where they're at. My team goes that extra mile to cut through bureaucratic red tape and get Hudson Valley families the benefits they've earned with the C.A.R.E.S. Van.

If you need help navigating anything from IRS returns to Social Security, or just want to talk with my team, hope you'll join one of August's events!

DELIVERING MAJOR FUNDING FOR STEWART INTERNATIONAL AIRPORT

Earlier this summer, I brought Department of Transportation leadership to Stewart International Airport to show them how federal infrastructure funding is opening the floodgates to private investments in the airport, and supercharging the entire region's economy.

Alongside Senators Schumer and Gillibrand, I'm proud to have secured more than \$24 million for Stewart to complete runway infrastructure overhauls, keeping the airport a hub for growth and at the forefront of airport safety.

I 'll keep working every day to make transportation safer for Hudson Valley families and drive the economic investments to help our airports thrive.

CELEBRATING AVIATION AT THE ORANGE COUNTY AIR SHOW

Last Sunday was the perfect day for the Orange County Airshow. As a member of the House Armed Services Committee and the first West Point graduate to represent the Academy in Congress, it was great to see the West Point Parachute Team and the Air Force Thunderbirds in action.

Thank you to County Executive Neuhaus for his kind hospitality and to the exemplary leaders of the 105th Airlift Wing.

LOWERING THE COST OF PRESCRIPTION DRUGS

Thanks to the Inflation Reduction Act, millions of seniors will see significant savings on their prescription drug costs in 2026. For the first time, this legislation allows Medicare to negotiate the price of medications with big pharmaceutical companies.

Many pharmaceutical companies are already lowering the price of some of the most commonly used prescription drugs as a result of the negotiations with Medicare, before the negotiated price even goes into effect, including the blood thinners Eliquis and Xarelto, diabetes medication Jardiance, and heart failure drug Entresto. (Contd. Pg 57)

PAT RYAN

(From Pg. 56)Once the negotiated prices officially go into effect in 2026, they're set to save \$6 billion for taxpayers and \$1.5 billion for seniors on Medicare.

The far-right wants to eliminate this provision - I'll keep fighting to protect it and for additional measures to lower drug prices and healthcare costs for every Hudson Valley family, like my Stopping Pharma's Ripoffs and Drug Savings For All Act that would make generic, lower cost medications easier to produce and access.

GETTING VETERANS THE BENEFITS THEY EARNED

Last weekend marked two years since the PACT Act was signed into law, expanding healthcare and benefits to veterans exposed to toxins while serving our country.

If you or a veteran you know need assistance accessing PACT Act or any VA benefits - whether it's requesting the necessary military records, filing a claim, or signing up for healthcare, please reach out to my office at (845) 443-2930 or here on my website.

CONGRATULATING AN OUTSTANDING HUDSON VALLEY COLLEGE STUDENT

A huge congratulations to Poughkeepsie's own Cody Gibbs for being named one of the White House's HBCU Scholars for this year!

The Arlington High School graduate was one of only 111 students from Historically Black Colleges and Universities (HBCUs) awarded the honor.

What an accomplishment - the Hudson Valley is proud of you, Cody!

Kirsten is committed to lowering prescription drug costs and putting money back in the pockets of Americans.

Last week, as a direct result of Kirsten's efforts to pass the Inflation Reduction Act, the Biden-Harris administration announced historic Medicare savings and lower costs for 10 commonly used prescription drugs. These negotiated drugs are some of the most expensive and most frequently prescribed in the Medicare program and are used to treat conditions such as heart disease, diabetes, and cancer.

The new prices will go into effect for people with Medicare Part D prescription drug coverage beginning January 1, 2026. \

4. Helping government employees

When a retired federal worker needed to secure her retirement annuity payments from the Office of Personnel Management (OPM), but could not get an update for months, she reached out to Kirsten's office for help. Kirsten's team contacted OPM, and within weeks, her annuity was processed and calculated a retroactive payment of \$10,000. Going forward she will receive a monthly payment of \$1,800.

Gillibrand Announces Nearly \$44 Million in Federal Grants to Support Homeless and At-Risk Veterans and Their Families Across NYS

WASHINGTON, D.C. - Today, U.S. Senator Kirsten Gillibrand announced \$43,952,503 in federal grants to support community organizations that work to prevent homelessness and protect at-risk veterans and their families across New York State. The funding was allocated through the Department of Veterans Affairs' Supportive Services for Veteran Families program, financing community organizations' efforts to rehouse veterans and their families, identify more suitable housing options for them, and prevent the imminent loss of veterans' homes.

"Our brave veterans have put their lives on the line to protect us, and it's unacceptable that after years of service to their country, so many end up on the streets," said Senator Gillibrand. "These grants will help community organizations across New York provide more housing and services to homeless and at-risk veterans. I'm proud to announce this funding and will continue to fight to reduce veteran homelessness in New York and across the country."

Organization Name	Grant Amount
HELP Social Service Corporation	\$2,786,637.00
Westchester Community Opportunity Program, Inc. (WestCOP)	\$4,041,934.00
Catholic Charities of the Roman Catholic Diocese of Syracuse NY	\$1,267,160.00
Soldier On of Delaware, Inc.	\$4,217,748.00
Utica Center for Development, Inc. Veterans & Community Housing Coalition Inc.	\$929,259.00
Economic Opportunity Council Of Suffolk Inc.	\$1,075,529.00
Albany Housing Coalition, Inc. Volunteers of America-Greater New York, Inc.	\$2,736,728.00
Services for the UnderServed, Inc.	\$595,842.00
The Jericho Project	\$3,085,929.00
Veterans One-stop Center of WNY, Inc.	\$13,934,951.00
University of Vermont and State Agricultural College	\$5,447,289.00
	\$836,189.00
	\$2,997,308.00

Each year, Gillibrand calls on appropriators to fund the Supportive Services for Veteran Families, HUD-VA Supportive Housing (HUD-VASH), and Homeless Providers Grant and Per Diem programs to reduce veteran homelessness and help more veterans receive housing assistance.



Welcome to Kirsten's New York Minute!

Here's what she's been up to this week:

1. Delivering federal dollars for New York's airports

New York's airports serve millions of passengers each year and Kirsten is committed to securing federal dollars to modernize and boost safety at airports across the state.

Just this week, she secured:

Over \$24 million to repair damage to the runway at Stewart International Airport so passengers traveling in and out of the Hudson Valley can take off and land safely. [Read more.](#)

Over \$5 million to support airport safety and infrastructure improvement projects at 9 airports across the North Country and Upstate New York. [Read more.](#)

Over \$1.8 million to upgrade airport infrastructure at Niagara Falls International Airport and Buffalo Niagara International Airport to boost aviation safety for Western New York travelers. [Read more.](#)

2. Equipping New York fire departments

New York's firefighters risk their lives every day to protect our communities and Kirsten is fighting to make sure they have the protective gear and resources they need.

This week, Kirsten delivered nearly \$6.5 million to fire departments across Upstate New York. The funding will help recruit, hire and train firefighters, and provide protective gear and supplies to emergency personnel across 38 fire departments.

3. ATTN: Medicare enrollees



Honoring our Vietnam Veterans



Vietnam Veterans often returned home to a divided country and were not always given the recognition they deserved. This week, we hosted a Vietnam Veteran Commemorative Pinning Ceremony to right that wrong and offer a long-overdue acknowledgment and appreciation of their sacrifice. It was a privilege to honor these veterans and present each veteran with a commemorative Vietnam Veteran Lapel Pin to symbolize the nation's deep appreciation for their service.

JOE BIDEN COMMITTED IMPEACHABLE OFFENSES

Since 2023, House Republicans have obtained and reviewed thousands of pages of financial records, text messages, emails, and witness testimony detailing the severe corruption of the President and his family.

From the influence-peddling scheme that leveraged Joe Biden's position as Vice President to establish the 'brand' and generate millions of dollars for the Biden family and their business associates to obstructing our impeachment inquiry and the criminal investigation into Hunter Biden, we can confidently conclude that President Biden and his family abused public office for personal financial gain.

This week, we House Republicans released 291-page report reveals the incriminating evidence that President Biden abused his office and violated his oath as President and Vice President by engaging in an influence-peddling scheme to enrich his family.

We have exposed the truth through this detailed investigation, and on behalf of the American people, we are dedicated to ensuring that President Biden and the Biden Crime Family are held accountable.

My Agriculture Plan

Agriculture is the cornerstone of our community. NY-24 continues to stand out as a premier agricultural hub in the Northeast, boasting the largest dairy district in New York,

and Wayne County is the largest apple-producing county outside of Washington State. Wyoming County also ranks among the top maple syrup producers in the nation, and the Finger Lakes region is renowned for its numerous vineyards, orchards, and specialty crops. These producers drive the economy of Upstate and Western New York, providing jobs to local workers and supplying our grocery stores and schools with nutritious local products.

This week, I released my comprehensive agriculture plan, which illustrates a comprehensive approach that promotes pro-farmer agricultural policies and backs programs that keep our food industry thriving. My plan details how I will unlock the potential of our rural communities, counteract hostile foreign interference in our agriculture sector, and provide farmers and producers with the certainty and opportunities they need to thrive.

My Broadband Access Plan

Addressing the unique needs of NY-24's robust agriculture community and sprawling rural landscape requires bold action and a comprehensive, innovative solution. In today's world, internet connections shape our access to education, health care, and employment opportunities.

I'm committed to supporting policies that increase competition and connectivity. Every New Yorker needs to have access to a robust marketplace of broadband options. In addition, we must lay the groundwork for new technologies, such as 5G, that promise connectivity for a lower cost. To accomplish these objectives, I am supporting a package of bills in Congress that will deliver real results. My plan unleashes private sector innovation to foster competition and bring costs down while providing vital oversight over agencies tasked with carrying out these broadband efforts.

I remain dedicated to overcoming bureaucratic red tape to bring fast, reliable, affordable broadband to all corners of NY-24.



MOLINARO MEMO

Welcome to the Molinaro Memo: catching you up on my latest moves and work for Upstate New York!
Demanded Hochul Deport Illegal Immigrants With Criminal Record Following Arrest

Gianfranco Torres-Navarro, a Peruvian gang leader wanted for 23 murders, was in the country illegally, allowed to roam Endicott for months, and was arrested in Vestal. This comes shortly after a teenage girl was raped by an illegal immigrant in the Capital region, a 21 year-old woman was suffocated to death in Central NY and a young woman was sexually assaulted in the Catskills. I'm demanding Governor Kathy Hochul notify ICE and swiftly deport illegal immigrants with a criminal record to ensure the safety of New Yorkers and prevent any additional heinous crimes from taking place.

Contd. Pg. 59)

Molinaro Memo (From Pg. 58)

Hosted 'Broome County's Next Chapter' Listening Session

I hosted a listening session with local elected leaders, business owners, community organizations & representatives from Fortune 500 companies as part of my 'Broome's Next Chapter' initiative. During the listening session, panelists discussed priorities major employers look for when investing in a community, such as location, access to transportation, relationships with local businesses, and educational facilities to implement workforce development programs. This conversation served as valuable insight to drive our next chapter of success for Broome.

'Coffee With Your Congressman' In Otsego County

Had a 'Coffee With Your Congressman' at Pathfinder Village in Otsego County. It was wonderful to hear from everyone on how I can continue fighting for Upstate New York and their priorities! Thanks to everyone who came out.

Hosted Vietnam Veteran Pinning Ceremony

As part of my August Action Plan, I hosted a pinning ceremony in Greene County for Vietnam War Veterans and their families. It was my honor to welcome and recognize these veterans and their families for their service to our country.

Selected Delaware Opportunities For Child Advocacy Award

I was honored to select Delaware Opportunities in Hamden for the 2024 Angels in Adoption Award for New York's 19th Congressional District. This award recognizes individuals and organizations who contribute to the development and well-being of children and youth in their communities. Angel Award winners are invited to Washington to celebrate and meet with their member of Congress, participate in roundtable discussions with peers from across the county, and receive advocacy training. Delaware Opportunities has been serving our community for years and ensures no child is ever left behind. Congratulations on this well-deserved recognition.

August Action

We've had a successful August Action so far and I'm looking forward to continuing listening and learning from Upstate New York as I travel across all eleven counties. Here's what I've been up to lately.

Such a fun day playing field games and connecting families & individuals with local services at my Think DIFFERENTLY Field Day in Columbia County.

Had a fun time in Sullivan County at the Grahamsville Fair with everyone!

Stopped at Yazy's Market in Accord for a fill up and snacks for the road!

Had a blast at the second annual Leeds Sunflower Festival.

Stopped by the Town of Copake for their huge Bicentennial Parade in Columbia County.

Toured the stabilization facility in Dutchess County with Guthrie Lourdes Hospital. We're working to bring these lifesaving services to Broome. Anyone who's dealing with a mental health or substance use crisis must be able to access support.

Always grateful to stop by and say thank you to the Johnson City Police officers that keep us safe everyday!

Great visit at the Otsego County Fire & Law Enforcement Training facility in Oneonta.

Enjoyed my stop at Crumhorn Mountain in Otsego County. I'm proud to have fought for \$2 million to be included in the FY25

House Appropriations bills to preserve the beautiful forests & wetlands across this landscape.

As August comes to a close, I want to take a moment to reflect on the key issues and developments that have shaped this month. From bipartisan efforts to local victories, our work continues to put the priorities of Upstate New York front and center.

From the start, I have been dedicated to working across party lines and representing every person in my district, no matter their political affiliation. I assure you that this commitment will remain unwavering.

A Peruvian gang leader, responsible for 23 murders, was arrested in Vestal, NY.

This news comes shortly after a 15-year-old girl was raped by an illegal immigrant in the Capital Region, a 21-year-old was suffocated to death in Central New York, and a young woman was sexually assaulted and strangled by an illegal immigrant in the Catskills.

I have sent a letter and called on Gov. Hochul to deport any illegal immigrant with a criminal record, to end our sanctuary state status, and to allow local law enforcement to coordinate with ICE.

Enough is enough. They are putting the safety of our communities at risk.

Have you seen my new TV ad?

This month, I continued to fight to protect our seniors. As healthcare costs rise, it's crucial that we ensure affordable and accessible healthcare for all, especially our elderly population.

I'm committed to defending the healthcare benefits our seniors have earned and depend on.

- Rep. Molinaro Calls For Federal Action To Reverse Gov. Hochul's Cuts To Disability & Senior Support Services

I'm thrilled to see CAPCO's next cycle of funding for early childhood programs take off. Investing in early childhood education is essential for the future of our communities.

These programs lay the foundation for lifelong learning and success, and I'm proud to support initiatives that benefit our youngest learners.

-CAPCO Begins Next Cycle of Funding for Early Childhood Program

I've joined a number of my colleagues in calling on Speaker Mike Johnson to protect clean energy tax credits.

As we navigate the challenges of transitioning to a sustainable energy future, it's crucial to support policies that balance environmental responsibility with economic practicality. These credits have helped to spur innovation, incentivize investment, and create good jobs.

- 18 House Republicans ask Johnson not to target IRA clean energy tax credits

School Food Service Professionals Gather

Two-day conference focused on the power of food and the impact of healthy eating for students



[Liberty, NY] -Food service professionals from throughout Sullivan County gathered last week for a two-day conference at the Michael Ritchie Big Barn, where they heard the message of the power of food from The Center for Discovery's Department of Nourishment Arts, were certified in Serv Safe by SUNY Sullivan and participated in hands on food preparation led by Lennox Hill Teaching Kitchen.

The conference was presented by the School Nutrition Action Coalition, a network of organizations and Sullivan County schools working together to bring 2 free, healthy, plant slant meals for every student, every day in Sullivan County schools. Food service staff engaged in discussions and hands on learning exploring how by cooking from scratch (with whole, fresh ingredients), school food programs can provide delicious, nutritious meals for students.

"School breakfast and lunch are so important to the physical health and learning of our students. The idea of this conference was to inspire scratch cooking and offer resources to support that goal," said Sullivan 180 CEO Denise Frangipane. "We are fortunate to have such dedicated individuals working in our schools. Several people said how much they appreciate the time together and the hands-on experience. The School Nutrition Action Coalition is here to support their work."

Attendees experimented with healthy, plant slant lunch items and enjoyed meals and great conversation against the backdrop of Thanksgiving Farm.

"A Single Bite + the Catskills Food Hub was happy to curate the lunch prepared by the Neversink General Store," said Audrey Garro, Executive Director of A Single Bite. "Many of the items used throughout the conference were sourced from our own local farms including Burns Farm, Somewhere in Time, Sprouting Dreams and the Center's Thanksgiving Farm. The items are reflective of the produce A Single Bite + Catskills Food Hub will be sourcing for Sullivan County school cafeterias."

"Cornell Cooperative Extension Sullivan County is so pleased with the conference turnout and our partnership with Sullivan 180, SNAC, school food service professionals, and Sullivan County's rich agricultural sector," said Melinda Meddaugh, CCE Sullivan Ag & Food Systems Issue Leader. "Working to bring fresh, healthy foods to our kids is just one way to keep local dollars circulating in our home community, while promoting healthy outcomes for young people where they're at. We look forward to continuing the work together."

"We are so pleased that so many food service staff from across the county came out to learn more about farm to school and scratch cooking from the Lennox Hill Teaching Kitchen," said Katie Sheehan-Lopez, Regional Farm to School Coordinator. "School districts in Sullivan County have made so much progress in getting foods from local farms onto students' trays. We are looking forward to seeing more exciting foods on school lunch menus this school year."

Sullivan 180 is facilitating the School Nutrition Action Coalition with support from a USDA grant. The Coalition includes leadership from: A Single Bite + the Catskills Food Hub; CCE Sullivan; Harvest New York; Sullivan BOCES; Sullivan 180; SUNY Sullivan; The Center for Discovery, Fallsburg, Liberty, Livingston Manor, Monticello Roscoe and Sullivan West school districts.

To learn more please contact Sullivan 180 at 845.295.2680.

Sullivan 180 is working to build a healthy community, one degree at a time, through people, places and policy with support from Bold Gold Media Group, Manor Ink, The River Reporter, The Sullivan County Democrat and WJFF Radio Catskill. Learn more at Sullivan180.org or Facebook.com/Sullivan180inc.



4th Annual FALLSBURG FALL FESTIVAL

Hosted by: Kiwanis of Woodridge, New York Foundation, Inc.

Saturday, 9/21/24, 10 A.M. – 4 P.M.
Green Avenue, Woodridge, NY

VENDORS



FOOD

Hula Hoop
Contest

GAMES

RAFFLES

*Children's Games,
Crafts, and More*

LIVE ENTERTAINMENT

To sign up for the Hula Hoop Contest (kids and adults must use hoops provided), or receive additional info, please contact Diane at dsenn10151@aol.com or Debbie at djacobsen1114@yahoo.com.

Festival Sponsored by: Jeff Bank,
Murray's Chicken, Mountain Service Distributors,
Colonial Memorial Funeral Homes, and Catskill Hudson Bank.

FREE PARKING AND ADMISSION!



FOR MORE INFORMATION:
845-292-5910 EXT. 0
PublicHealthEducation@sullivanny.us
Visit our Facebook page for updates!

2nd Annual HEALTHFEST

Join us for a collection of community based organizations here for you and your health, and other activities:

- Health Screenings & Education
- Monarch Butterfly Catch, Tag and Release
- Nature Trail, Games, & Prizes
- Local Vendors, Resources, and More!



Saturday, September 14th
Rain or Shine!



11am - 3pm



Hanofee Park

129-143 Sunset Lake Road, Liberty, NY

Admission is **FREE**, and there's something for everyone to enjoy. So, gather your friends and family for a fun filled afternoon!



Sullivan County
Rural Health Network



Public Health
Sullivan County
Department of Public Health

medical
reserve
corps





ELEMENTARY SOCIAL SKILLS

Registration is open for Grades K-5.

Action Toward Independence offers fun and interactive Social Skills groups for children with Autism and other developmental, learning, emotional, and behavioral disabilities. These informative sessions cover topics that promote positive behavior, improve interactions with others and build confidence.

- Manners
- Listening
- Hygiene
- Emotions

Social skills classes will be held in person at ATI Main Office at 309 E Broadway in Monticello, NY. Parents may be required to attend some sessions with their child to offer guidance and support.

FOR MORE INFORMATION:

Family Peer Advocate
(845) 794-4228
info@atitoday.org

Funding is provided by OPWDD. There is no cost to the student or family of students on the Autism Spectrum who receive or are eligible to receive OPWDD services.

Visit our website at

atitoday.org

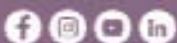

SCAN ME!

Leadership Sullivan Class 2024-2025 September - June

The mission of Leadership Sullivan is to cultivate informed and dedicated leaders from across the community who will use their collective experience and skills to enhance and enrich the quality of life for everyone in Sullivan County.

The Leadership Sullivan Program is designed to unlock participants' leadership potential through educational initiatives that expand their understanding of the County, refine communication skills, and boost organizational and problem-solving abilities. This program offers a unique environment for personal growth while fostering the development and well-being of those around you. Elevate your potential, forge stronger connections, and enhance your knowledge.

For more information or to apply please visit:

**Leadership Sullivan - Sullivan County Chamber of
Commerce - NY (catskills.com)
Deadline for applications is August 31st, 2024!**

For Details, Contact:

**Sullivan County Chamber of Commerce & Industry, Inc.
foundation@catskills.com
845-791-4200 x1
196 Bridgeville Road, Monticello, NY 12701 USA**



VET 2 VET OF SULLIVAN COUNTY PRESENTS:

★ **SALUTING SPOUSES** ★

A SUPPORT GROUP FOR SPOUSES OF VETERANS AND SERVICE MEMBERS

PLEASE JOIN US EVERY **2ND** AND **4TH** MONDAY OF
THE MONTH FROM 5:30PM TO 7:00PM.

ACTION TOWARD INDEPENDENCE
309 E BROADWAY
MONTICELLO, NY 12701

FOR UPCOMING GROUPS, WE WILL BE HAVING GUEST SPEAKERS, FIELD TRIPS
AND OTHER FUN ACTIVITIES TO HELP SPOUSES, AND THEIR FAMILIES, BECOME
MORE INFORMED OF SERVICES THAT ARE AVAILABLE.

Eligibility and Pre-Registration Required

Please call our Veteran Advocate at (845) 794-4228
or email mkleman@atitoday.org



Sullivan County Intervention Line for Parents and Teens

Are you a parent struggling with your family?
Are you a teen having problems at home?

Help is available now!

We are here anytime you need to talk.

Give us a call or send us a text and someone will always be there to listen and help you deal with your situation.



Text 845-372-1817
Call 866-372-2336

Calls and texts are answered 24/7

A program of the DRC

Sullivan County Text For Teens

Monday - Friday
4pm-10pm
Saturday & Sunday
5pm-12am



Hey...I really need to talk to someone. Can you help?



Free & confidential support
Someone who can listen and help
Text as often as you need!

We're Here to Listen:
Bullying - Eating Disorders -
Self-Harm - Homeless/Runaway -
Pregnancy - Problems at Home -
Relationship Issues - LGBTQ+ -
Divorce - School Issues -
Substance Use -
Physical/Mental/Sexual Health -
and more!

Text "Start" to:
845-637-9486

OFF HOURS:
Call 1-888-750-2266, option 2



Text for Teens is supported by a Grant of the Mother Cabrini Health Foundation



Rewarding lives. Healthy communities.

COVID-19 Vaccines Save Lives

Who will you protect?



Friends

Amigos

Family

¿A quien protegerás?

Get the facts.



Familia

Obtenga los hechos.

Talk to your healthcare provider about the COVID vaccine.



Comunidad

Hable con su proveedor de salud sobre la vacuna del COVID-19.

#VaccinateSullivan

For more information, visit www.sullivanny.us



GET SIGNED UP TODAY FOR OUR UPCOMING CERTIFICATION CLASS !!

Contact:

Alyssa Wowk
(845) 645-6544

awowk@chowc.net

Sullivan County Department of Social Services is looking for families who can help fulfill the **DESPERATE NEED** for ages **8-18!**



FOSTER HOMES NEEDED!





FALL FUND-RAISING DINNER

Saturday, Oct. 26, 2024

6:30 - 9:30 pm

at the Phoenicia Diner

5681 Route 28 (1 mile east of Phoenicia)

Come for the fishing...

Stay for the fun!

Help us celebrate our fishing heritage!

3-Course Buffet Dinner

Silent Auction

Bucket Raffle

**Stay tuned for information about cost and
how to purchase tickets.**



**STARTS JANUARY
2024!**

Are You Ready?



Life Skills Group

WORK READINESS EDITION

This series is tailored for 16 to 25-year-olds with developmental, learning, emotional, and behavioral disabilities. It helps prepare individuals for the workforce by developing skills such as appropriate workplace behavior, social etiquette, time management, and interview techniques. Other topics include wearing proper clothing and using social cues, such as a good handshake.

Every Friday from 5:00pm to 6:15pm

309 East Broadway

Monticello, NY 12701

FOR MORE INFORMATION:

(845) 794-4228

info@atitoday.org



SCAN ME!

Funding is provided by OPWDD. There is no cost to the student or family of students on the Autism Spectrum who receive or are eligible to receive OPWDD services.

Visit our website at

atitoday.org





Middle School Social Skills

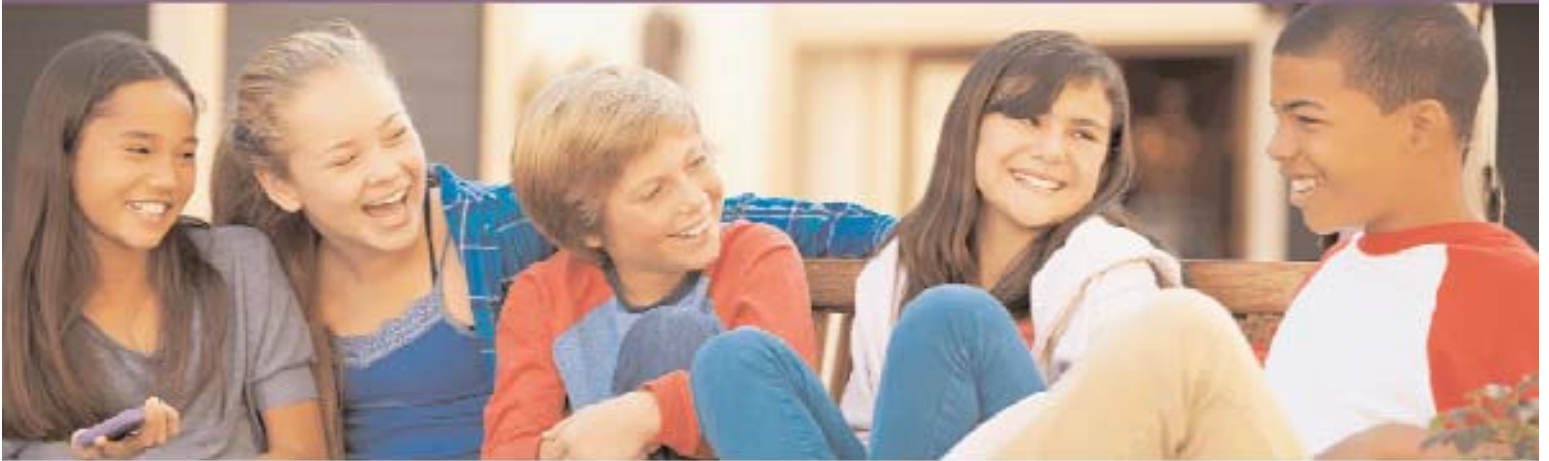

Action Toward Independence offers interactive and fun Social Skills groups for children with developmental, learning, emotional, and behavioral disabilities grades 5 - 8.

The informative sessions cover age-appropriate topics for pre-teens and teens that promote positive behavior, respectful communication, and building confidence.

Social skills classes will be held in person at ATI Main Office at 309 E Broadway in Monticello, NY

For more information:
Family Peer Advocate
(845) 794 - 4228
info@atitoday.org

Funding is provided by OPWDD. There is no cost to the student or family of students on the Autism Spectrum who receive or are eligible to receive OPWDD services.

Visit our website at

atitoday.org



SCAN ME!





A poster for a 'Back to School' event. At the top left is the 'My Brother's Keeper' (MBK) logo featuring a circle of diverse faces. At the top center is the NAACP logo. At the top right is a purple square with an orange asterisk-like symbol and the text 'THE BLACK LIBRARY'. Below these logos, it says 'Hosted by My Brother's Keeper' and 'Hosted by The Black Library'. The main text reads 'Join us at the BACK TO SCHOOL' in large yellow letters. Below that, it says 'FREE !!! School Supplies and Backpack Giveaway!'. The date and time are 'Saturday August 31, 2024 Noon- 3:00 PM' and the location is '418 Broadway, Monticello NY'. There are illustrations of a girl's face, a boy's face, a backpack, a ruler, and a pencil.

Hosted by
My Brother's Keeper

Hosted by
The Black Library

Join us at the
BACK TO SCHOOL

FREE !!!
School Supplies and Backpack Giveaway!

Saturday August 31, 2024
Noon- 3:00 PM
418 Broadway, Monticello NY



A poster for the 'Oktoberfest Beer Festival'. At the top left is a small illustration of a beer stein. The text says 'SAVE THE DATE!' in orange, followed by 'OKTOBERFEST BEER FESTIVAL' in large, stylized letters. Below that, it says 'BEER • FOOD • MUSIC AT HOLIDAY MOUNTAIN' and 'OCTOBER 26TH, 2024'. At the bottom left is the 'SKI HOLIDAY MOUNTAIN' logo. On the right side, there is a large illustration of two overflowing beer mugs.

SAVE THE DATE!
OKTOBERFEST BEER FESTIVAL

BEER • FOOD • MUSIC
AT HOLIDAY MOUNTAIN

OCTOBER 26TH,
2024

SKI HOLIDAY MOUNTAIN

Veteran Peer Support



**Vet 2 Vet offers
Veteran Peer Support.
Call to speak with our Veteran
Peer Advocates.
We didn't fight alone while
we served, we don't need
to fight alone at home.**

Vet 2 Vet



**Sullivan County
NEW YORK**

NYC Joseph P. Dwyer Peer Support Program

Call or email us to register!

845-794-4228

vet2vet@atitoday.org

309 E Broadway Suite A

Monticello, NY 12701

Cornell Cooperative Extension | Sullivan County

ALZHEIMER'S ASSOCIATION



Parkinson's Support Group



Registration is preferred but walk-ins are welcome!

Parkinson's disease can be different for everyone. While there's no cure for Parkinson's disease, certain lifestyle changes can help manage symptoms and improve overall quality of life.

WHEN:

4:00 PM - 5:30 PM

July 10

Aug. 14

Sept. 11

Oct. 9

Nov. 13.

REGISTER:

 (845) 292-6180 ext. 122

 sullivancrc@cornell.edu

 <https://tinyurl.com/3s4uhzc9>



ANYONE WITH QUESTIONS CAN CALL ANGELA @ 845-292-8715

OR EMAIL:

FOLKPLUS@GMAIL.COM

This program is supported with a grant from the NYS Department of Health, OFA, CCE/Caregiver Resource Center Program and the Alzheimer's Association.



Daniel Pierce Library

Summer Reading Program

2024

ADVENTURE BEGINS AT YOUR **LIBRARY.**
 with our Reading Incentives

June 30 to August 30
 All ages

Children Ages 0-5 Years and 6-11 Years
 Read all summer, log the number of books and minutes read to receive prizes!

"Tweens", Teens, and Adults
 Log the number of books and minutes read and for every 4 books you read you will be entered into our SRP drawing!

Book BINGO: Ages 6 - 11 years, "Tweens" Grades 5-8, Teens Grades 9-12 and Adults.

Bookmark Contest: Ages 5-7 years, 8-11 years and 12-18 years
 Students are invited to submit an original design for the library's Summer Reading Program Bookmark!

Pick up reading logs, BINGO sheets and bookmark contest entry forms at the library or download them from our website.

Children 5-18 years old will be eligible for a single-day splash pass generously provided by the Kartrite Resort & Waterpark upon completion of our summer program.

For more details, please check out our website @ www.danielpiercelibrary.org



P.O. Box 268 • 328 Main Street • Grahamsville, NY 12740
 845-985-7233 • dpl@rcls.org • www.danielpiercelibrary.org

MANOR FLEA!!!!



FUN SHOPPING - FREE PARKING



MAY 4 + 5
 JUNE 1ST + 2
 AUGUST 3 + 4
 SEPTEMBER 7 + 8
 OCTOBER 12 + 13
 NOVEMBER 23 + 24
 DECEMBER 14 + 15



CATSKILL BREWERY 672-OLD RYE ST, LIVINGSTON MANSION NY
WWW.CATSKILLBREWERY.COM

Save the date ...

Catholic Charities 2024 Golf for Charity Outing



Monday, September 16
 West Hills Country Club Middletown, NY

For foursomes, sponsorships, and tee signs,
 contact: Kristin.Jensen@cccsos.org

SAVE THE DATE

Grown Here

A FARM-TO-TABLE EXPERIENCE

LOCALLY SOURCED
 THREE-COURSE DINNER
 SILENT AUCTION & MORE!

**SATURDAY
 OCT 19**
 AT 5:00 PM

HONORING
 TONY MORINO
 PAUL CILIBERTO
 MAUREEN & STEVE PLAIN HALL OF FAME
 RUTH ANN WARD
 DISTINGUISHED SERVICE AWARD
 ORANGE BANK & TRUST
 JEFF BANK
 FRIEND OF THE CLUB

THE CLUBHOUSE
 AT CIRCLEVILLE PARK
 60 CREAMERY ROAD, CIRCLEVILLE, NY 10919

**BOYS & GIRLS CLUBS
 OF TOWN OF WALLKILL INC.**
 SERVING NORTHERN ORANGE & SULLIVAN COUNTIES

LIMITED NUMBER OF TICKETS AVAILABLE
 845.342.8833 | BGCORANGE.ORG

ALL PROCEEDS BENEFIT THE BOYS & GIRLS CLUBS OF NORTHERN ORANGE & SULLIVAN COUNTIES.

ACCESSIBILITY IN THE WORKPLACE

New York System Change Inclusive Opportunity Network "NYSCION" Mid-Hudson Region will be hosting a 4-part virtual series for employers!

Discover how enhancing workplace accessibility cannot only increase diversity, but also boost your bottom line by tapping into a broader talent pool and improving employee productivity!

SEPT
4TH

Disability Etiquette
Speakers: Joe Zesski
Northeast ADA Center
10am-11am Via Zoom

SEPT
18TH

ADA & Employment Overview
Speakers: Joe Zesski
Northeast ADA Center
10am-11am Via Zoom

SEPT
25TH

Key Considerations for Recruiting and Hiring Job Seekers with Disabilities
Speakers: Jeffrey Tamburo
Northeast ADA Center
10am-11am Via Zoom

OCT
2ND

Making the Business Case: Strategy for Promoting ADA Implementation
Speakers: Jeffrey Tamburo
Northeast ADA Center
10am-11am Via Zoom

REGISTER NOW!



WE ARE YOUR DOL
STATE OF NEW YORK | Department of Labor



For questions or accommodations, please contact: Scott Curry | sidney.curry@sullivanyny.us | 845-807-0587

WHAT CAN YOU DO WITH A Daniel Pierce Library Card?
Explore everything your library card gives you!





Read any way you like
Printed books, magazines, and newspapers, eBooks and audiobooks.



Listen at home or on the go
eAudiobooks and music for streaming or download.



Get online and get going
Free Wi-Fi

 Borrow movies, documentaries, TV series and more

Learn something new 24/7

Learn a new language FREE with Rosetta Stone

Online classes and research materials ready when you are

Download the Libby App 

Borrow instead of buy

Check out books, magazines, e-audiobooks and audiobooks from all 47 RCLS Libraries

Download the RCLS Gateway App 

Entertain your kids – or yourself!

Passes to Mohonk Preserve and the Jim and Nancy Valleys Museum

Unlimited access to thousands of digital comics, graphic novels and manga 

There's even more to explore with your library card.

- ▶ Online programming, databases and research materials
- ▶ Export reading recommendations
- ▶ Internet access and computers to use

SIGN UP TODAY! It's **FREE** and easy!
Visit the Daniel Pierce Library for more details.

SHARE THE NUMBER

SPREAD THE WORD

CALL OR TEXT

988

CHAT

988LIFELINE.ORG



There is hope.



988 SUICIDE & CRISIS LIFELINE

VOICESUNITED4CHANGE'S VIRTUAL

YOUTH SUPPORT GROUP

JOIN US!





Join us for a peer led, mental health, lesson based virtual support group for teens ages 13-17. Together we learn about our mental health and do an activity together. This group is completely free to join, and all supplies for the activity will be sent to your home. Space is limited for each group!

Contact Rebekah at rumarbashar@asfl.org for more information.

EVERY 1ST & 3RD

WEDNESDAY

@ 6:30 PM

VOICESUNITED4CHANGE'S VIRTUAL

PARENT SUPPORT GROUP

JOIN US!





Join us for a peer led virtual support group for parents of children with mental health challenges. Together we have time for conversation and an activity. This group is completely free to join, and all supplies for the activity will be sent to your home. Space is limited for each group!

Contact Anne-Marie at afreitas@asfl.org for more information.

EVERY 2ND & 4TH

WEDNESDAY

@ 6:30 PM



What's Going On?

The Sullivan County Legislature is considering asking voters to determine whether all nine legislators should be elected every four years (which is the current process) or via staggered terms.

What Are Staggered Terms?

Staggered terms are created via elections where only part of the elected body - in this case, the Legislature - is up for election in a particular year.

Why Is the Legislature Considering This?

The Sullivan County Charter Review Commission has repeatedly recommended that not all legislator positions be up for election in the same year. The concern is that all nine could be replaced at the same time, leading to a loss of institutional knowledge and a steep learning curve, both of which could be detrimental to County operations and thus taxpayers.

What Is Being Proposed?

The County Charter currently requires all nine (9) legislator seats to be put up for vote every four (4) years. This proposal would ask voters to approve a change to the Charter, stipulating that at the next County Legislature election in November 2027, four (4) positions would be up for vote for a term of three (3) years, running from January 2028 to December 2030; and five (5) positions would be up for vote for a term of five (5) years, running from January 2028 to December 2032. After those terms run out, all nine (9) positions would revert to four-year terms, but as a result, there would be a Legislature election every two (2) years, thus “staggering” legislators’ terms of office.





Why Are the Terms Being Proposed This Way?

The Legislature has considered this change for several years, and with New York State now mandating some local elections only occur in even-numbered years, this is seen as the most efficient way to split up the positions. If voters approve this change, legislators will conduct a random selection (for example, picking names out of a hat or drawing straws) to determine which positions will be up for three years and which will be up for five years.

So What's Next?

A public hearing on the proposed local law is set for Thursday, September 5 at 8:45 a.m. in the Hearing Room of the Government Center, 100 North Street, Monticello. Anyone who wishes to speak or hear about staggered terms is welcome. (Note that this will not be a Q&A session.) Anyone who cannot or will not attend the hearing can provide comment **at any time before the meeting** to Clerk of the Legislature Anmarie Martin by mail, addressed to her at 100 North Street, Monticello, NY 12701, or by email to anmarie.martin@sullivanny.us.

Legislators will then have to vote on whether or not to put the idea to voters. They are expected to make that decision at a special meeting immediately after the public hearing on Thursday, September 5 in the Hearing Room of the Government Center, 100 North Street, Monticello. The meeting will be public.

If the majority of legislators adopt the local law, the question will be put to voters as part of the General Election ballot this Election Day, Tuesday, November 5 (and in Early Voting/Absentee ballots). If a majority of voters say no, then the proposed local law will not be adopted, and no change will occur. If a majority of voters say yes, then preparations will begin as detailed above.

Who Can I Talk To More About This?

Your own legislator is your best resource on this and other County Legislature matters. A complete list of their contact information is available at <https://sullivanny.us/Departments/Legislature> or by calling 845-807-0435.

More information, as it becomes available, will be posted to www.sullivanny.us and on local and social media outlets.

HELP WANTED

Part time Bookkeeper
Call 845-321-1919

Typing Help Wanted Experienced or Student.
Full/Part time. Work in Grahamsville. Busy
LawOffice. William Brenner (845) 985-7411

**Blooming Green Lawn
and Landscape Sevice**
Part time/Full time work.
Salary based on experience.
Call: 845-665-3348
or 945-985-0516

2BR APARTMENT FOR RENT in Grahamsville.
Tri-Valley School District. Available immediately.
Call or Email 845-985-7411
or williamabrenner@hotmail.com

Classified Ads
Only \$5.00 a week!

The
**Gnome
Home**



Sell your handcrafted
items online from your
own little
virtual shop
at the

**Gnome Home
Virtual Mall**

Interested?

Send an email to:

gnomehomeinc@yahoo.com

**... or if you just want
to have some
'gnome made' fun..**

Visit the gnome's
virtual on-line local shop
at:

<http://www.gnomehomeinc.com>



"KNARF'S CLASSIC MOVIE I"

**ON AMAZON PRIME, NETFLIX
CLOUDBURST**

(1951)

The script is based on a play written by Leo Marks, a wartime cryptographer for the Special Operations Executive, and later the author of a memoir about his wartime work, *Between Silk and Cyanide* (1998).



The film takes place in 1946 in London. Canadian John Graham worked in the British resistance during the war. Now in this post-war era, he supervises the cryptology department for the British Service. His British wife Carol worked alongside him until she was expecting their first child. As they are out together one evening, Carol is killed in a hit-and-run. John searches for the driver and seeks revenge for Carol's death. He constructs an elaborate plot to avenge her death - literally eye for an eye.

Directed by Francis Searle, starring Robert Preston, and featuring Elizabeth Sellars, Harold Lang, Colin Tapley and Sheila Burrell. (Contd. Pg. 79)

Answer to last week's Trivia Question: Kurt Russell

This weeks' Trivia question:

What classic Italian beauty starred in *Two Women*?

(From Pg. 78)

KNARF'S CLASSIC MOVIE II ON AMAZON PRIME, NETFLIX DRIVE A CROOKED ROAD

(83 min. / Crime Thriller)

Eddie Shannon is a mechanic and race car driver, he was the choice of two bank robbers to help them with their getaway from a big heist. The heist requires someone drive at high speeds. Couple that with his ability to "soup up" engines. makes him the right choice to avoid capture after they robbed the public.



It's the old story sex lures the guy trying to be a respected man. The gangster's girlfriend, Barbara Mathews, used her charms to help persuade Eddie to assist with the crime. Eddie's dream –competitive racing The robbery would make it come true!

Barbara falls in love with Eddie, and secretly feels ashamed of leading him on. This makes Eddie realize he is being used. Summing it up in a life and death struggle for almost all involved.

Directed by Richard Quine, and starring Mickey Rooney as Eddie Shannon, Dianne Foster as Barbara Mathews, Kevin McCarthy as Steve Norris, Jack Kelly as Harold Baker, Harry Landers as Ralph, Jerry Paris as Phil, Paul Picerni as Carl, and Dick Crockett as Don

KNARF'S CLASSIC MOVIE III
EDDIE MULLER'S FILM NOIR ON TCM
12:00 AM EST SATURDAY
SEPTEMBER 18, 2021

HUMAN DESIRE



A 1954 American noir drama film directed by Fritz Lang and starring Glenn Ford, Gloria Grahame and Broderick Crawford.

It is loosely based on Émile Zola's 1890 novel *La Bête humaine*. The story had been filmed twice before: *La Bête humaine* in 1938, directed by Jean Renoir, and *Die Bestie im Menschen*, starring Ilka Grüning in 1920.

Korean War veteran Jeff Warren returns to his home town and accepts a job as a train engineer, driving streamliners, hauling passenger trains for the fictional Central National Railroad. Warren worked alongside Alec Simmons and was also a boarder in his home before going off to war. Alec's daughter Ellen is smitten with Jeff.

Stay safe, and stay well
Knarf Odnamoc
Gnome